

SYLVANIA

SERVICE MANUAL

**20" COLOR LCD TELEVISION
LC200SL8**

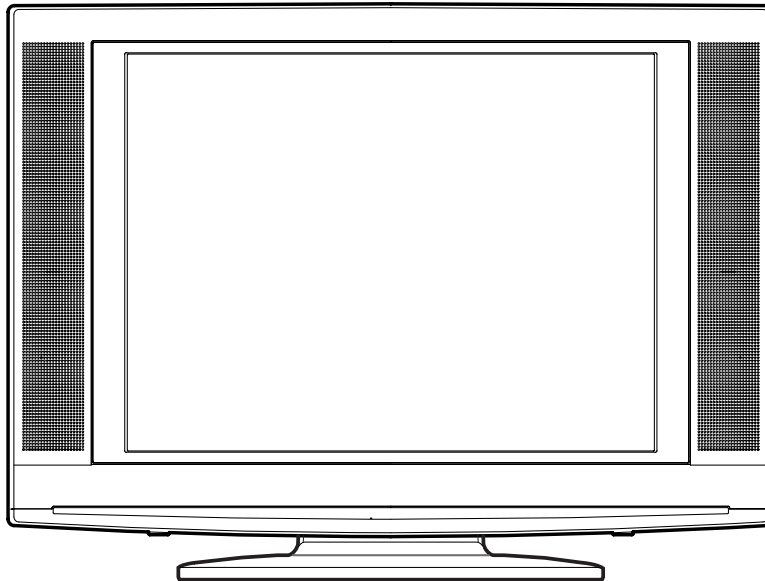

IMPORTANT SAFETY NOTICE

Proper service and repair is important to the safe, reliable operation of all Funai Equipment. The service procedures recommended by Funai and described in this service manual are effective methods of performing service operations. Some of these service special tools should be used when and as recommended.

It is important to note that this service manual contains various CAUTIONS and NOTICES which should be carefully read in order to minimize the risk of personal injury to service personnel. The possibility exists that improper service methods may damage the equipment. It also is important to understand that these CAUTIONS and NOTICES ARE NOT EXHAUSTIVE. Funai could not possibly know, evaluate and advice the service trade of all conceivable ways in which service might be done or of the possible hazardous consequences of each way. Consequently, Funai has not undertaken any such broad evaluation. Accordingly, a servicer who uses a service procedure or tool which is not recommended by Funai must first use all precautions thoroughly so that neither his safety nor the safe operation of the equipment will be jeopardized by the service method selected.

TABLE OF CONTENTS

Specifications	1-1
Important Safety Precautions	2-1
Standard Notes for Servicing	3-1
Cabinet Disassembly Instructions	4-1
Electrical Adjustment Instructions	5-1
How to initialize the LCD Television	6-1
Block Diagrams	7-1
Schematic Diagrams / CBA's and Test Points	8-1
Waveforms	9-1
Wiring Diagram	10-1
IC Pin Function Descriptions	11-1
Exploded Views	12-1
Mechanical Parts List	13-1
Electrical Parts List	14-1

The LCD panel is manufactured to provide many years of useful life. Occasionally a few non active pixels may appear as a tiny spec of color. This is not to be considered a defect in the LCD screen.

SPECIFICATIONS

< TUNER >

VHF/UHF Input : 75 ohm Unbal., F type

Intermediate Freq. : Picture 45.75 MHz, Sound 41.25 MHz

Description	Condition	Unit	Nominal	Limit
1. Video S/N	80dB	dB	---	>43
2. Audio S/N	80dB	dB	---	>45

< LCD PANEL >

Description	Condition	Unit	Nominal	Limit
1. Number of Pixels	Horizontal	pixels	640 x 3	---
	Vertical	pixels	480	---
2. Viewing Angle	Horizontal	°	-80 to 80	---
	Vertical	°	-65 to 70	---

< VIDEO >

Description	Condition	Unit	Nominal	Limit
1. Over Scan	Horizontal	%	5	---
	Vertical	%	5	---
2. Color Temperature	AT 80% WHITE FIELD	°K	11000	---
	x		0.276	±0.005
	y		0.282	±0.005
3. Resolution	Horizontal	line	400	---
	Vertical	line	350	---
4. Brightness	AT 100% WHITE FIELD	cd/m ²	320	---

< AUDIO >

All items are measured across 8 Ω load at speaker output terminal with L.P.F.

Description	Condition	Unit	Nominal	Limit
1. Audio Output Power	10% THD: Lch/Rch	W	1.0/1.0	0.8/0.8
2. Audio Distortion	500mW: Lch/Rch	%	1.5/1.5	3.0/3.0
3. Audio Freq. Response	-6dB: Lch	Hz	70 to 8 k	---
	-6dB: Rch	Hz	70 to 8 k	---
4. Audio S/N	VIDEO1	dB	---	>45/45
	VIDEO2	dB	---	>45/45

< ATSC >

Description	Condition	Unit	Nominal	Limit
1. RECEIVED FREQ. RANGE (-28dBm)	+	kHz	---	>100
	-			
2. ATSC DYNAMIC RANGE (min./max.)	VHF LOW BAND. CH.4	dBm	---	-76/0
	VHF HI BAND. CH.10			
	UHF BAND. CH.41			
3. ATSC SUSCEPTIBILITY TO RANDOM NOISE	VHF LOW BAND. CH.4	dB	---	<26
	VHF HI BAND. CH.10			
	UHF BAND. CH.41			
4. NTSC CO-CHANNEL INTERFERENCE	VHF LOW BAND. CH.4	dB	---	>-6
	VHF HI BAND. CH.10			
	UHF BAND. CH.41			
5. MULTIPATH	A	dB	---	<6
	B			
	C			
	D			
	E			
	F			
	FF			
	G			
6. Audio S/N (0dBfs)	Lch	dB	---	>50
	Rch			
7. Audio DIST. (0dBfs)	Lch	%	---	<3
	Rch			

Note: Nominal specifications represent the design specifications. All units should be able to approximate these. Some will exceed and some may drop slightly below these specifications. Limit specifications represent the absolute worst condition that still might be considered acceptable. In no case should a unit fail to meet limit specifications.

IMPORTANT SAFETY PRECAUTIONS

Prior to shipment from the factory, our products are strictly inspected for recognized product safety and electrical codes of the countries in which they are to be sold. However, in order to maintain such compliance, it is equally important to implement the following precautions when a set is being serviced.

Safety Precautions for LCD TV Circuit

1. **Before returning an instrument to the customer**, always make a safety check of the entire instrument, including, but not limited to, the following items:

a. Be sure that no built-in protective devices are defective and have been defeated during servicing. (1) Protective shields are provided on this chassis to protect both the technician and the customer. Correctly replace all missing protective shields, including any removed for servicing convenience. (2) When reinstalling the chassis and/or other assembly in the cabinet, be sure to put back in place all protective devices, including but not limited to, nonmetallic control knobs, insulating fishpapers, adjustment and compartment covers/shields, and isolation resistor/capacitor networks. **Do not operate this instrument or permit it to be operated without all protective devices correctly installed and functioning. Servicers who defeat safety features or fail to perform safety checks may be liable for any resulting damage.**

b. Be sure that there are no cabinet openings through which an adult or child might be able to insert their fingers and contact a hazardous voltage. Such openings include, but are not limited to, (1) spacing between the Liquid Crystal Panel and the cabinet mask, (2) excessively wide cabinet ventilation slots, and (3) an improperly fitted and/or incorrectly secured cabinet back cover.

c. **Antenna Cold Check** - With the instrument AC plug removed from any AC source, connect an electrical jumper across the two AC plug prongs. Place the instrument AC switch in the on position. Connect one lead of an ohmmeter to the AC plug prongs tied together and touch the other ohmmeter lead in turn to each tuner antenna input exposed terminal screw and, if applicable, to the coaxial connector. If the measured resistance is less than 1.0 megohm or greater than 5.2 megohm, an abnormality exists that must be corrected before the instrument is returned to the customer. Repeat this test with the instrument AC switch in the off position.

d. **Leakage Current Hot Check** - With the instrument completely reassembled, plug the AC line cord directly into a 120 V AC outlet. (Do not use an isolation transformer during this test.) Use a leakage current tester or a metering system that complies with American National Standards Institute (ANSI) C101.1 Leakage Current for Appliances and Underwriters Laboratories (UL) 1410, (50.7). With the instrument AC switch first in the on position and then in the off position, measure from a known earth ground (metal water pipe, conduit, etc.) to all exposed metal parts of the instrument (antennas, handle brackets, metal cabinet, screw heads, metallic overlays, control shafts, etc.), especially any exposed metal parts that offer an electrical return path to the chassis. Any current measured must not exceed 0.5 milli-ampere. Reverse the instrument power cord plug in the outlet and repeat the test.

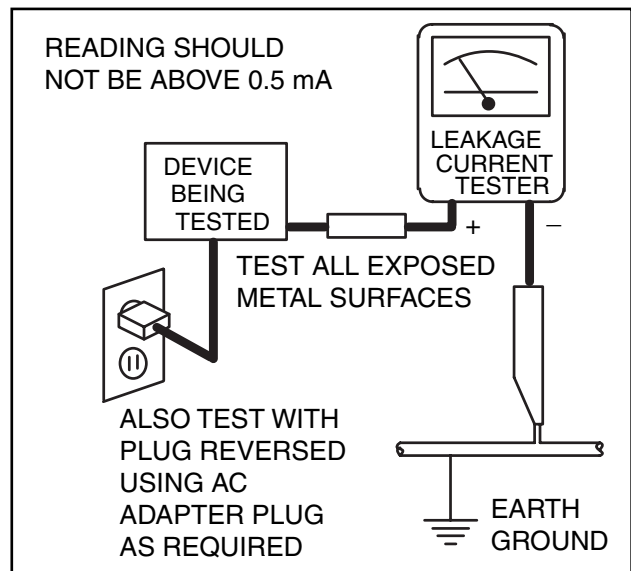

ANY MEASUREMENTS NOT WITHIN THE LIMITS SPECIFIED HEREIN INDICATE A POTENTIAL SHOCK HAZARD THAT MUST BE ELIMINATED BEFORE RETURNING THE INSTRUMENT TO THE CUSTOMER OR BEFORE CONNECTING THE ANTENNA OR ACCESSORIES.

2. Read and comply with all caution and safety-related notes on or inside the receiver cabinet, on the receiver chassis, or on the Liquid Crystal Panel.

- 3. Design Alteration Warning** - Do not alter or add to the mechanical or electrical design of this TV receiver. Design alterations and additions, including, but not limited to circuit modifications and the addition of items such as auxiliary audio and/or video output connections, might alter the safety characteristics of this receiver and create a hazard to the user. Any design alterations or additions will void the manufacturer's warranty and may make you, the servicer, responsible for personal injury or property damage resulting therefrom.
- 4. Hot Chassis Warning** -
 - a. Some TV receiver chassis are electrically connected directly to one conductor of the AC power cord and maybe safety-serviced without an isolation transformer only if the AC power plug is inserted so that the chassis is connected to the ground side of the AC power source. To confirm that the AC power plug is inserted correctly, with an AC voltmeter, measure between the chassis and a known earth ground. If a voltage reading in excess of 1.0V is obtained, remove and reinsert the AC power plug in the opposite polarity and again measure the voltage potential between the chassis and a known earth ground.
 - b. Some TV receiver chassis normally have 85V AC(RMS) between chassis and earth ground regardless of the AC plug polarity. This chassis can be safety-serviced only with an isolation transformer inserted in the power line between the receiver and the AC power source, for both personnel and test equipment protection.
 - c. Some TV receiver chassis have a secondary ground system in addition to the main chassis ground. This secondary ground system is not isolated from the AC power line. The two ground systems are electrically separated by insulation material that must not be defeated or altered.
- 5.** Observe original lead dress. Take extra care to assure correct lead dress in the following areas: a. near sharp edges, b. near thermally hot parts-be sure that leads and components do not touch thermally hot parts, c. the AC supply, d. high voltage, and, e. antenna wiring. Always inspect in all areas for pinched, out of place, or frayed wiring. Check AC power cord for damage.
- 6.** Components, parts, and/or wiring that appear to have overheated or are otherwise damaged should be replaced with components, parts, or wiring that meet original specifications. Additionally, determine the cause of overheating and/or damage and, if necessary, take corrective action to remove any potential safety hazard.
- 7. Product Safety Notice** - Some electrical and mechanical parts have special safety-related characteristics which are often not evident from visual inspection, nor can the protection they give necessarily be obtained by replacing them with components rated for higher voltage, wattage, etc. Parts that have special safety characteristics are identified by a  on schematics and in parts lists. Use of a substitute replacement that does not have the same safety characteristics as the recommended replacement part might create shock, fire, and/or other hazards. The product's safety is under review continuously and new instructions are issued whenever appropriate. Prior to shipment from the factory, our products are strictly inspected to confirm they comply with the recognized product safety and electrical codes of the countries in which they are to be sold. However, in order to maintain such compliance, it is equally important to implement the following precautions when a set is being serviced.

Precautions during Servicing

- A.** Parts identified by the **▲** symbol are critical for safety.
Replace only with part number specified.
- B.** In addition to safety, other parts and assemblies are specified for conformance with regulations applying to spurious radiation. These must also be replaced only with specified replacements.
Examples: RF converters, RF cables, noise blocking capacitors, and noise blocking filters, etc.
- C.** Use specified internal wiring. Note especially:
 - 1) Wires covered with PVC tubing
 - 2) Double insulated wires
 - 3) High voltage leads
- D.** Use specified insulating materials for hazardous live parts. Note especially:
 - 1) Insulation Tape
 - 2) PVC tubing
 - 3) Spacers
 - 4) Insulators for transistors.
- E.** When replacing AC primary side components (transformers, power cord, etc.), wrap ends of wires securely about the terminals before soldering.
- F.** Observe that the wires do not contact heat producing parts (heat sinks, oxide metal film resistors, fusible resistors, etc.)
- G.** Check that replaced wires do not contact sharp edged or pointed parts.
- H.** When a power cord has been replaced, check that 5~6 kg of force in any direction will not loosen it.
- I.** Also check areas surrounding repaired locations.
- J.** Use care that foreign objects (screws, solder droplets, etc.) do not remain inside the set.
- K.** Crimp type wire connector
The power transformer uses crimp type connectors which connect the power cord and the primary side of the transformer. When replacing the transformer, follow these steps carefully and precisely to prevent shock hazards.
Replacement procedure
 - 1) Remove the old connector by cutting the wires at a point close to the connector.
Important: Do not re-use a connector (discard it).
 - 2) Strip about 15 mm of the insulation from the ends of the wires. If the wires are stranded, twist the strands to avoid frayed conductors.
 - 3) Align the lengths of the wires to be connected. Insert the wires fully into the connector.
 - 4) Use the crimping tool to crimp the metal sleeve at the center position. Be sure to crimp fully to the complete closure of the tool.
- L.** When connecting or disconnecting the internal connectors, first, disconnect the AC plug from the AC supply outlet.
- M.** When installing parts or assembling the cabinet parts, be sure to use the proper screws and tighten certainly.

Safety Check after Servicing

Examine the area surrounding the repaired location for damage or deterioration. Observe that screws, parts and wires have been returned to original positions. Afterwards, perform the following tests and confirm the specified values in order to verify compliance with safety standards.

1. Clearance Distance

When replacing primary circuit components, confirm specified clearance distance (d) and (d') between soldered terminals, and between terminals and surrounding metallic parts. (See Fig. 1)

Table 1: Ratings for selected area

AC Line Voltage	Region	Clearance Distance (d), (d')
110 to 130 V	U.S.A. or Canada	≥ 3.2 mm (0.126 inches)

Note: This table is unofficial and for reference only. Be sure to confirm the precise values.

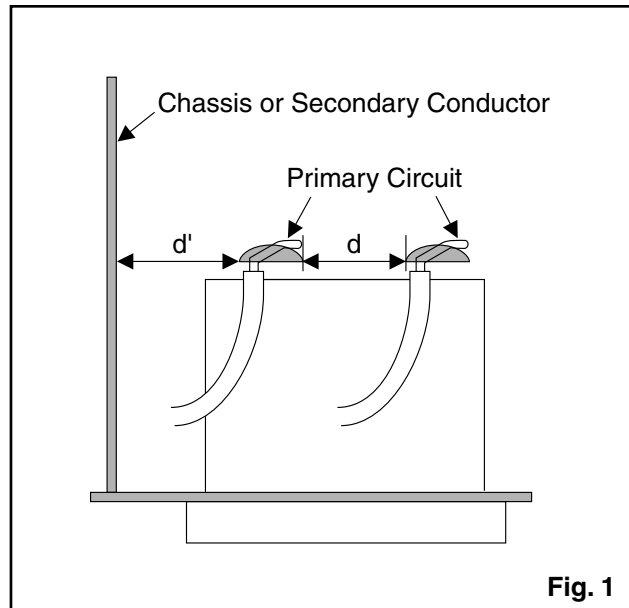

Fig. 1

2. Leakage Current Test

Confirm the specified (or lower) leakage current between B (earth ground, power cord plug prongs) and externally exposed accessible parts (RF terminals, antenna terminals, video and audio input and output terminals, microphone jacks, earphone jacks, etc.) is lower than or equal to the specified value in the table below.

Measuring Method: (Power ON)

Insert load Z between B (earth ground, power cord plug prongs) and exposed accessible parts. Use an AC voltmeter to measure across both terminals of load Z. See Fig. 2 and following table.

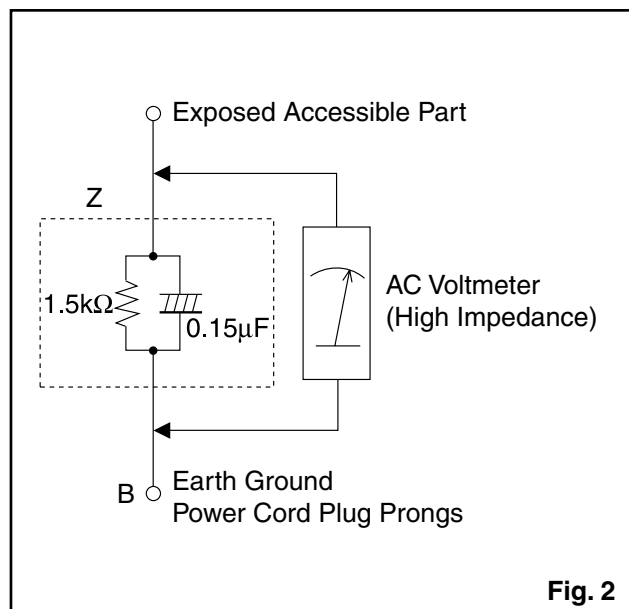

Fig. 2

Table 2: Leakage current ratings for selected areas

AC Line Voltage	Region	Load Z	Leakage Current (i)	Earth Ground (B) to:
110 to 130 V	U.S.A. or Canada	0.15 μ F CAP. & 1.5 k Ω RES. Connected in parallel	$i \leq 0.5$ mA rms	Exposed accessible parts

Note: This table is unofficial and for reference only. Be sure to confirm the precise values.

STANDARD NOTES FOR SERVICING

Circuit Board Indications

1. The output pin of the 3 pin Regulator ICs is indicated as shown.

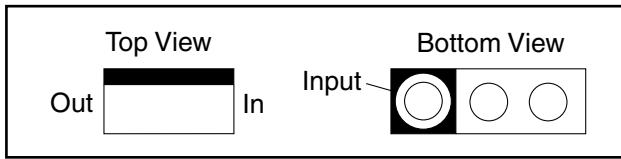

2. For other ICs, pin 1 and every fifth pin are indicated as shown.

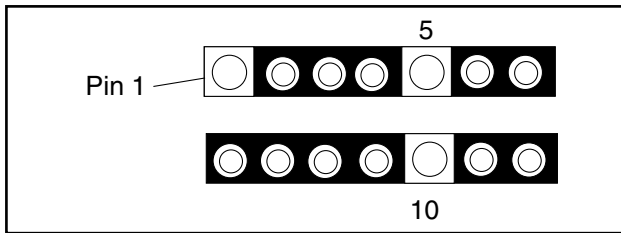

3. The 1st pin of every male connector is indicated as shown.

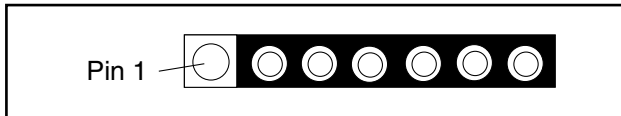

Pb (Lead) Free Solder

Pb free mark will be found on PCBs which use Pb free solder. (Refer to figure.) For PCBs with Pb free mark, be sure to use Pb free solder. For PCBs without Pb free mark, use standard solder.

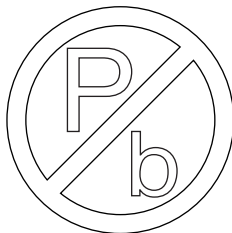

Pb free mark

How to Remove / Install Flat Pack-IC

1. Removal

With Hot-Air Flat Pack-IC Desoldering Machine:

1. Prepare the hot-air flat pack-IC desoldering machine, then apply hot air to the Flat Pack-IC (about 5 to 6 seconds). (Fig. S-1-1)

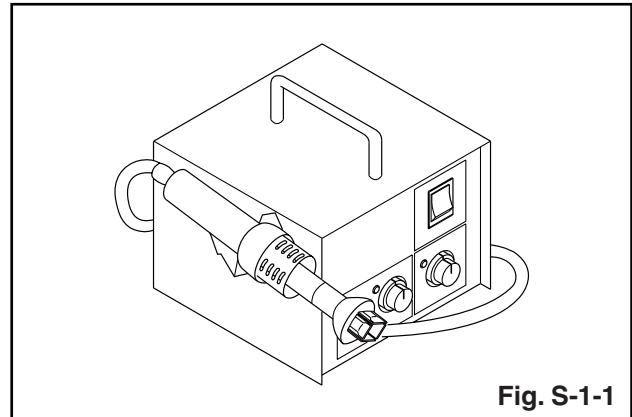

Fig. S-1-1

2. Remove the flat pack-IC with tweezers while applying the hot air.
3. Bottom of the flat pack-IC is fixed with glue to the CBA; when removing entire flat pack-IC, first apply soldering iron to center of the flat pack-IC and heat up. Then remove (glue will be melted). (Fig. S-1-6)
4. Release the flat pack-IC from the CBA using tweezers. (Fig. S-1-6)

CAUTION:

1. The Flat Pack-IC shape may differ by models. Use an appropriate hot-air flat pack-IC desoldering machine, whose shape matches that of the Flat Pack-IC.
2. Do not supply hot air to the chip parts around the flat pack-IC for over 6 seconds because damage to the chip parts may occur. Put masking tape around the flat pack-IC to protect other parts from damage. (Fig. S-1-2)

3. The flat pack-IC on the CBA is affixed with glue, so be careful not to break or damage the foil of each pin or the solder lands under the IC when removing it.

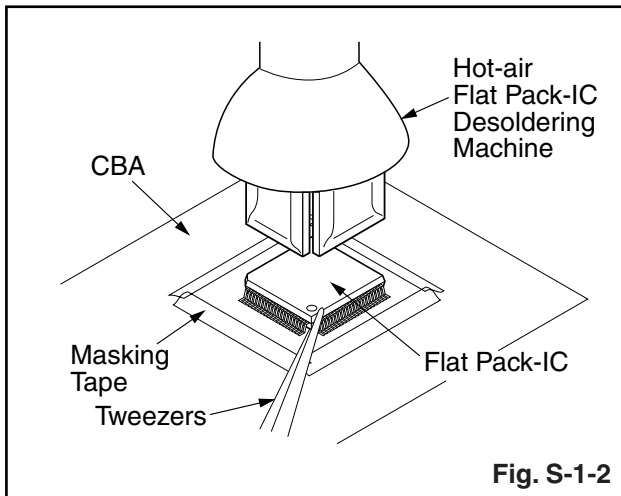

With Soldering Iron:

1. Using desoldering braid, remove the solder from all pins of the flat pack-IC. When you use solder flux which is applied to all pins of the flat pack-IC, you can remove it easily. (Fig. S-1-3)

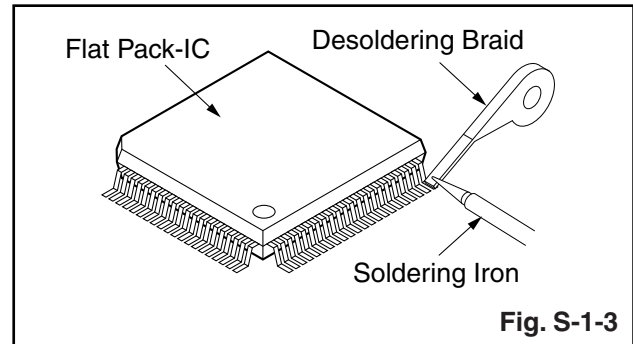

2. Lift each lead of the flat pack-IC upward one by one, using a sharp pin or wire to which solder will not adhere (iron wire). When heating the pins, use a fine tip soldering iron or a hot air desoldering machine. (Fig. S-1-4)

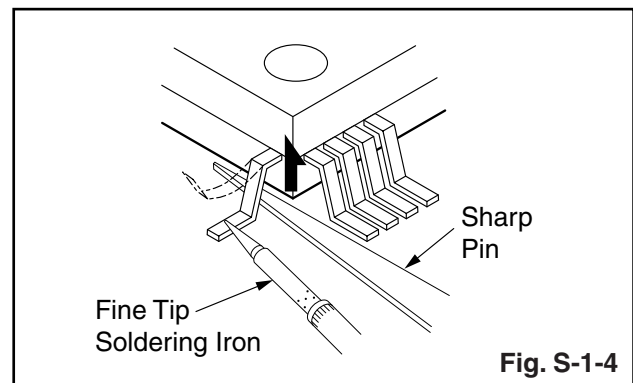

3. Bottom of the flat pack-IC is fixed with glue to the CBA; when removing entire flat pack-IC, first apply soldering iron to center of the flat pack-IC and heat up. Then remove (glue will be melted). (Fig. S-1-6)
4. Release the flat pack-IC from the CBA using tweezers. (Fig. S-1-6)

With Iron Wire:

1. Using desoldering braid, remove the solder from all pins of the flat pack-IC. When you use solder flux which is applied to all pins of the flat pack-IC, you can remove it easily. (Fig. S-1-3)
2. Affix the wire to a workbench or solid mounting point, as shown in Fig. S-1-5.
3. While heating the pins using a fine tip soldering iron or hot air blower, pull up the wire as the solder melts so as to lift the IC leads from the CBA contact pads as shown in Fig. S-1-5.
4. Bottom of the flat pack-IC is fixed with glue to the CBA; when removing entire flat pack-IC, first apply soldering iron to center of the flat pack-IC and heat up. Then remove (glue will be melted). (Fig. S-1-6)
5. Release the flat pack-IC from the CBA using tweezers. (Fig. S-1-6)

Note: When using a soldering iron, care must be taken to ensure that the flat pack-IC is not being held by glue. When the flat pack-IC is removed from the CBA, handle it gently because it may be damaged if force is applied.

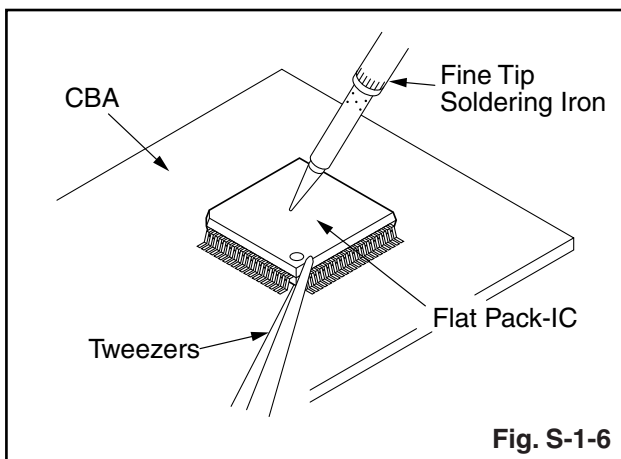
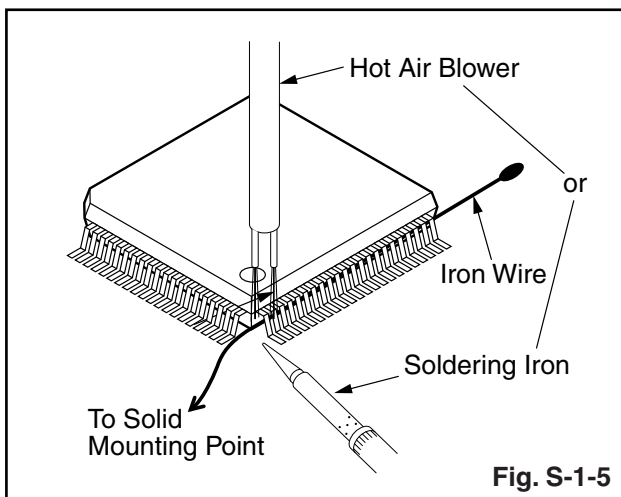

2. Installation

1. Using desoldering braid, remove the solder from the foil of each pin of the flat pack-IC on the CBA so you can install a replacement flat pack-IC more easily.
2. The "●" mark on the flat pack-IC indicates pin 1. (See Fig. S-1-7.) Be sure this mark matches the 1 on the PCB when positioning for installation. Then presolder the four corners of the flat pack-IC. (See Fig. S-1-8.)
3. Solder all pins of the flat pack-IC. Be sure that none of the pins have solder bridges.

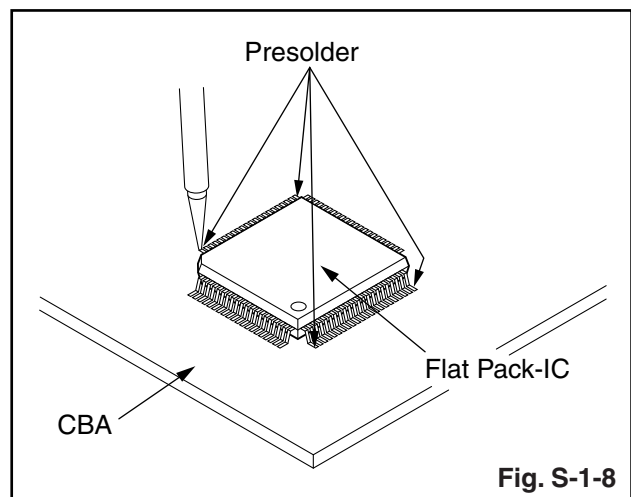
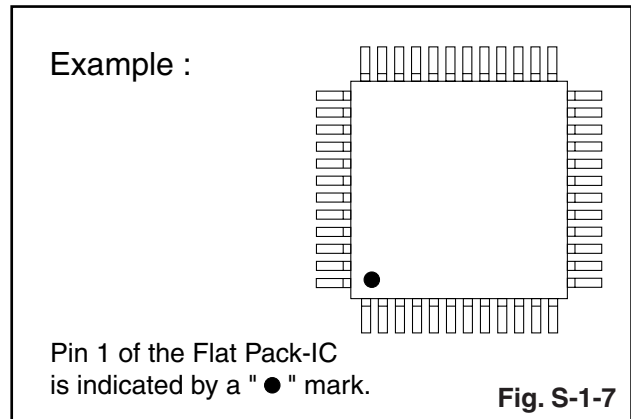

Instructions for Handling Semi-conductors

Electrostatic breakdown of the semi-conductors may occur due to a potential difference caused by electrostatic charge during unpacking or repair work.

1. Ground for Human Body

Be sure to wear a grounding band (1 MΩ) that is properly grounded to remove any static electricity that may be charged on the body.

2. Ground for Workbench

Be sure to place a conductive sheet or copper plate with proper grounding (1 MΩ) on the workbench or other surface, where the semi-conductors are to be placed. Because the static electricity charge on clothing will not escape through the body grounding band, be careful to avoid contacting semi-conductors with your clothing.

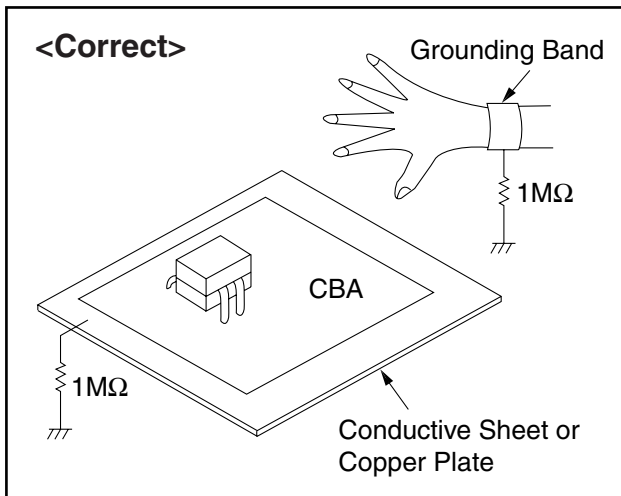
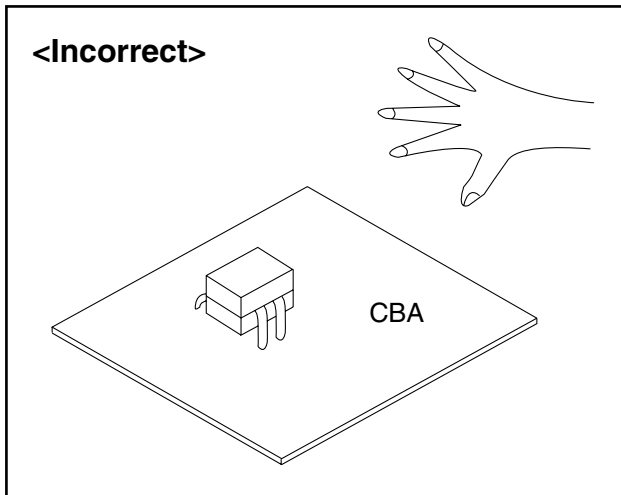

CABINET DISASSEMBLY INSTRUCTIONS

1. Disassembly Flowchart

This flowchart indicates the disassembly steps for the cabinet parts, and the CBA in order to gain access to item(s) to be serviced. When reassembling, follow the steps in reverse order. Bend, route and dress the cables as they were.

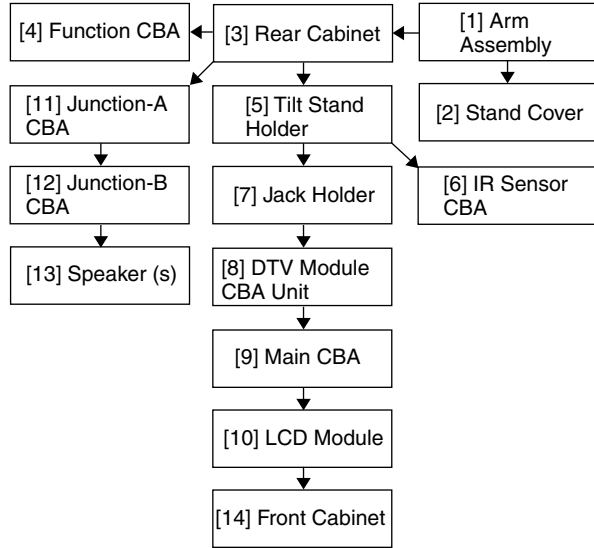

2. Disassembly Method

Step/ Loc. No.	Part	Removal		
		Fig. No.	Remove/*Unhook/ Unlock/Release/ Unplug/Unclamp/ Desolder	Note
[1]	Arm Assembly	D1	4(S-1), 6(S-2)	---
[2]	Stand Cover	D1	-----	---
[3]	Rear Cabinet	D1	10(S-3), (S-4)	---
[4]	Function CBA	D2 D3	5(S-5), *CL1107	---
[5]	Tilt Stand Holder	D2	2(S-6)	---
[6]	IR Sensor CBA	D2 D3	(S-7), *CL1104, Washer	---
[7]	Jack Holder	D2	(S-8)	---
[8]	DTV Module CBA Unit	D2 D3	8(S-9), *CL801, *CL802, *CN61, *CN62, *CN401, *CN402, *CN403, *CN1201, *CN1202, Module PCB Holder	---

Step/ Loc. No.	Part	Removal		
		Fig. No.	Remove/*Unhook/ Unlock/Release/ Unplug/Unclamp/ Desolder	Note
[9]	Main CBA	D2	-----	---
[10]	LCD Module	D2	11(S-10)	---
[11]	Junction-A CBA	D2	Desolder	---
[12]	Junction-B CBA	D2	Desolder	---
[13]	Speaker (s)	D2	4(S-11), Speaker Holder (s)	---
[14]	Front Cabinet	D2	-----	---

↓ (1) ↓ (2) ↓ (3) ↓ (4) ↓ (5)

Note:

- (1) Order of steps in procedure. When reassembling, follow the steps in reverse order. These numbers are also used as the Identification (location) No. of parts in figures.
- (2) Parts to be removed or installed.
- (3) Fig. No. showing procedure of part location
- (4) Identification of parts to be removed, unhooked, unlocked, released, unplugged, unclamped, or desoldered.
P = Spring, L = Locking Tab, S = Screw, CN = Connector
* = Unhook, Unlock, Release, Unplug, or Desolder
e.g. 2(S-2) = two Screws (S-2),
2(L-2) = two Locking Tabs (L-2)
- (5) Refer to the following "Reference Notes in the Table."

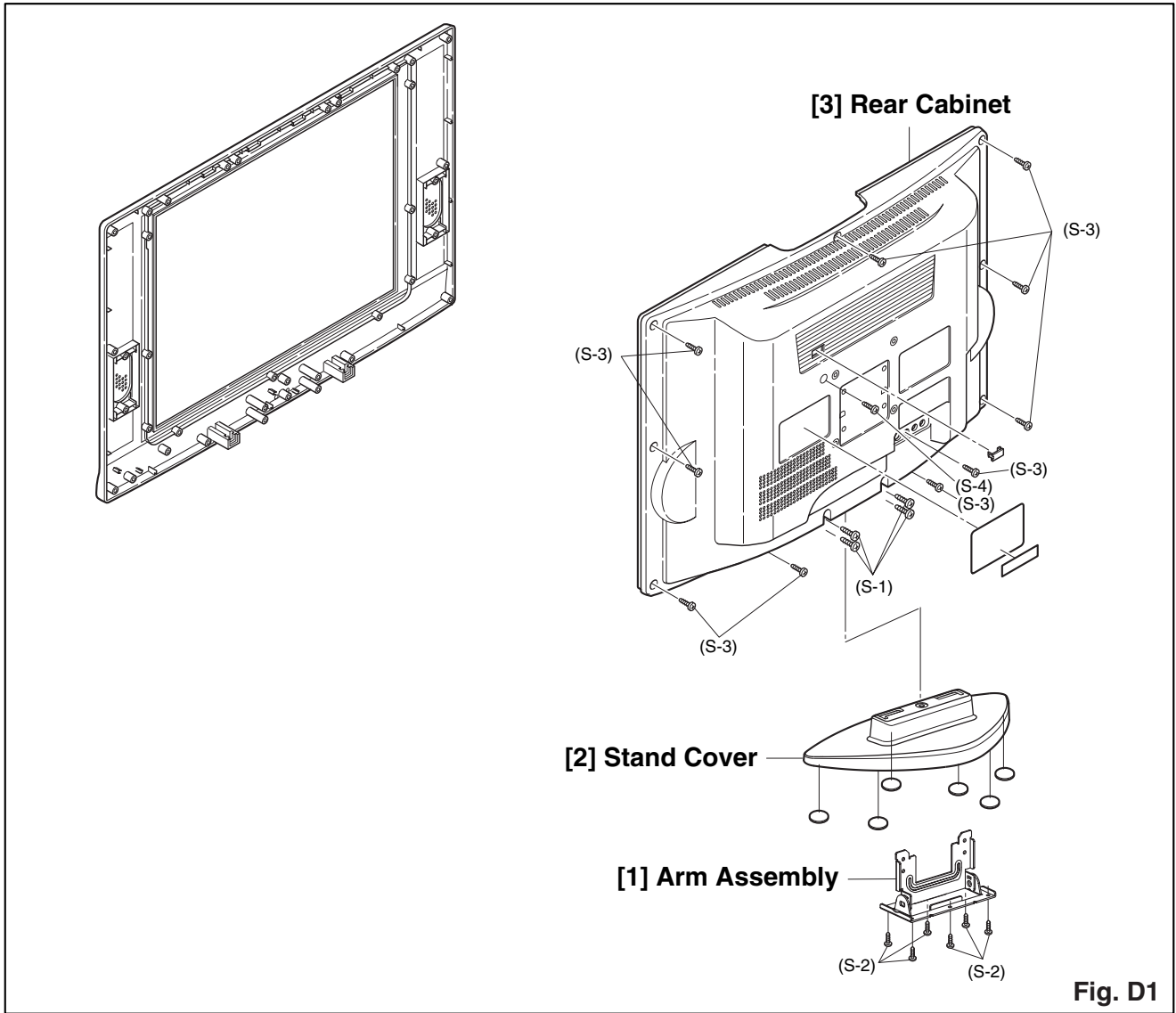
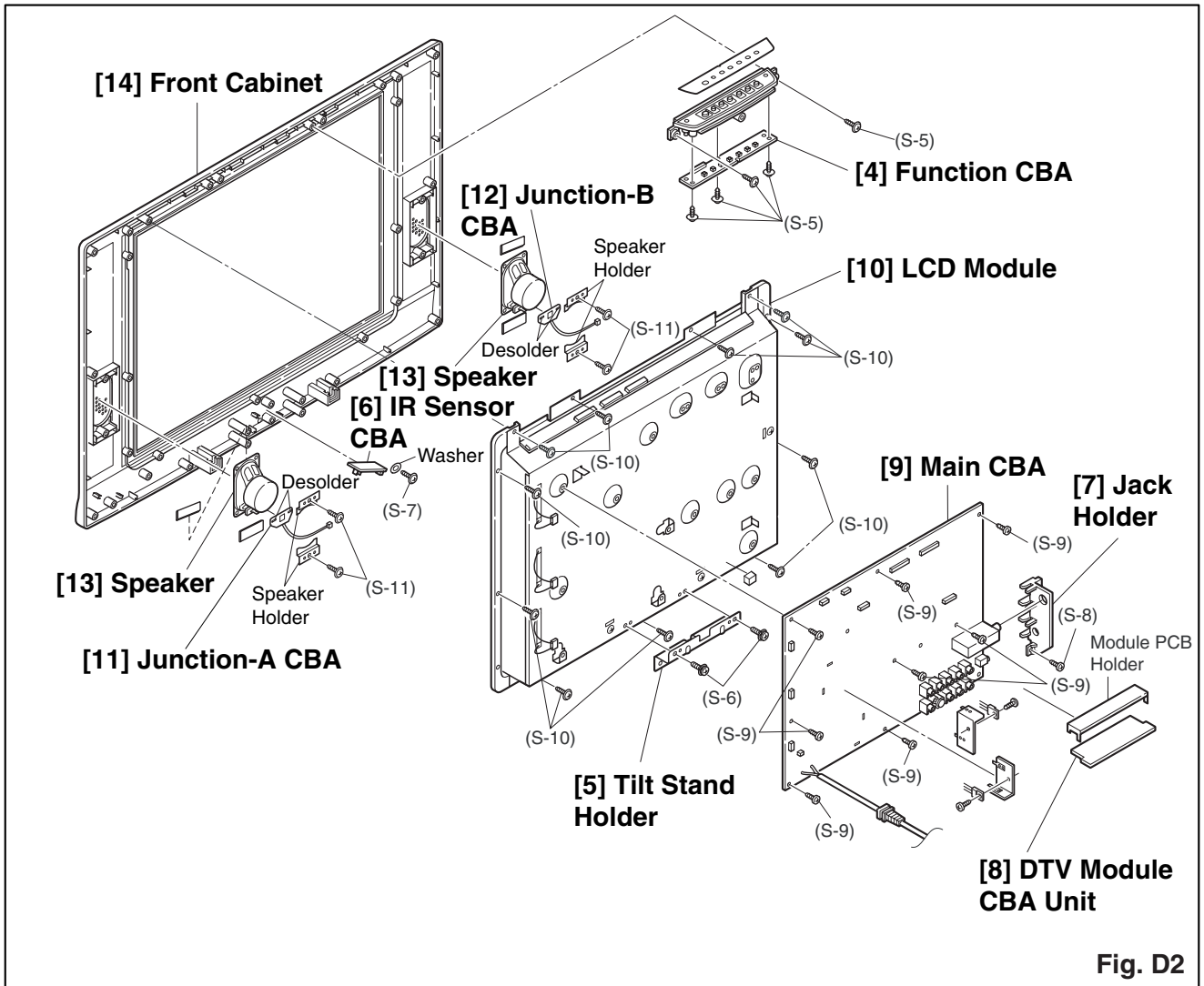

Fig. D1



TV Cable Wiring Diagram

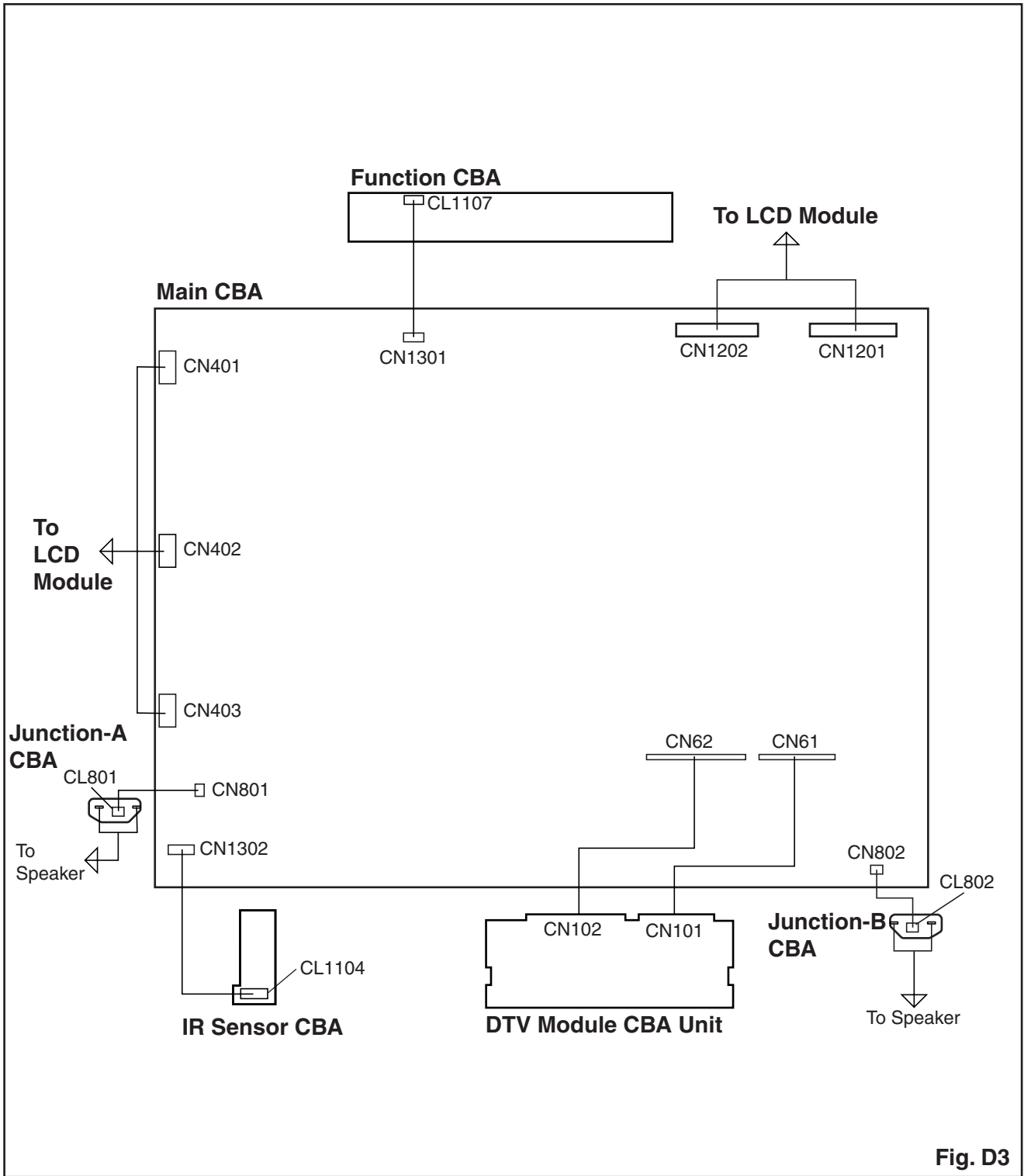

Fig. D3

ELECTRICAL ADJUSTMENT INSTRUCTIONS

General Note: “CBA” is abbreviation for “Circuit Board Assembly.”

Note: Electrical adjustments are required after replacing circuit components and certain mechanical parts. It is important to perform these adjustments only after all repairs and replacements have been completed. Also, do not attempt these adjustments unless the proper equipment is available.

Test Equipment Required

1. DC Voltmeter
2. NTSC Pattern Generator (Color Bar W/White Window, Red Color, Dot Pattern, Gray Scale, Monoscope, Multi-Burst)
3. Remote control unit
4. Color Analyzer

How to make the Service remote control unit:

Cut “A” portion of the attached remote control unit as shown in Fig. 1.

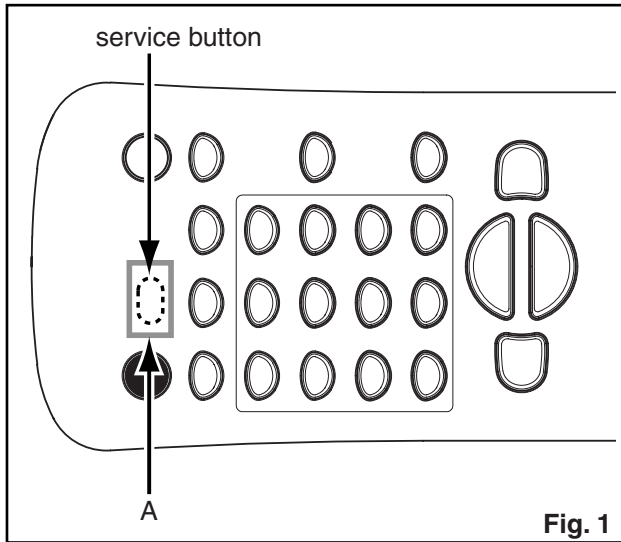

How to set up the service mode:

Service mode:

1. Use the service remote control unit.
2. Turn the power on. (Use main power on the TV unit.)
3. Press the service button on the service remote control unit as shown in Fig. 1.

1. Initial Setting

General: Enter the Service mode. (See page 5-1.)

Set the each initial data as shown on table 1 below.

Table 1: Initial Data

Item	Button (on the service remote control)	Data Value
RF-BRT	[SETUP] → [1]	127
RF-CNT		190
RF-CLR-R		75
RF-CLR-B		75
RF-TNT		128
RF-SHR		112
V-BRT	[SETUP] → [2]	127
V-CNT		190
V-CLR-R		70
V-CLR-B		70
V-TNT		128
V-SHR		112
S-BRT	[SETUP] → [3]	125
S-CNT		190
S-CLR-R		65
S-CLR-B		80
S-TNT		128
S-SHR		112
D1-BRT	[SETUP] → [4]	127
D1-CNT		170
D1-CLR-R		70
D1-CLR-B		70
D1-TNT		128
D1-SHR		112

Item	Button (on the service remote control)	Data Value
D2-BRT	[SETUP] → [5]	128
D2-CNT		180
D2-CLR-R		85
D2-CLR-B		85
D2-TNT		128
D2-SHR		112
D3-BRT	[SETUP] → [6]	120
D3-CNT		170
D3-CLR-R		80
D3-CLR-B		80
D3-TNT		128
D3-SHR		112
DT-BRT	[SETUP] → [7]	137
DT-CNT		190
DT-CLR-R		70
DT-CLR-B		75
DT-TNT		128
DT-SHR		112
COR(C/D1)	[VOL ▽] → [1]	128
C-COR(C/D2)		128
COB(C/D1)	[VOL ▽] → [3]	128
C-COB(C/D2)		128
DR(C/D1)	[VOL ▽] → [4]	128
C-DR(C/D2)		128
DB(C/D1)	[VOL ▽] → [6]	128
C-DB(C/D2)		128

The following adjustment normally are not attempted in the field. Only when replacing the LCD Panel then adjust as a preparation.

2. White Balance Adjustment

Purpose: To mix red, green and blue beams correctly for pure white.

Symptom of Misadjustment: White becomes bluish or reddish.

Test Point	Adj. Point	Mode	Input
Screen	VOL. ▽ buttons	[RF/VIDEO1] C/D1 [VIDEO2] C/D2	White Purity (APL 80%) or (APL 20%)
M. EQ.		Spec.	
Pattern Generator, Color analyzer		(at White APL 80%) $x = 0.276 \pm 0.03$ (0.246 to 0.306) $y = 0.282 \pm 0.03$ (0.252 to 0.312) (at White APL 20%) $x = 0.276 \pm 0.01$ (0.266 to 0.286) $y = 0.282 \pm 0.01$ (0.272 to 0.292)	

Figure

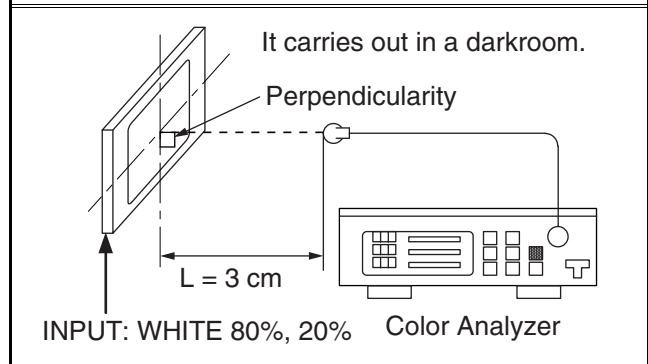

Note: Use the service remote control unit

- Operate the unit for more than 20 minutes.
- Input the White Purity.
- Set the color analyzer to the CHROMA mode and bring the optical receptor to the center on the LCD-Panel surface after zero point calibration as shown above.

Note: The optical receptor must be set perpendicularly to the LCD Panel surface.

- [RF/VIDEO1]**
Enter the Service mode. Press [VOL ▽] button on the remote control unit and select "C/D1" mode.

[VIDEO2]
Enter the Service mode. Press [VOL ▽] button on the remote control unit and select "C/D2" mode.

5. [RF/VIDEO1]----(APL 80%)
Press [6] button to select "DB(C/D1)" for Blue adjustment. Press [4] button to select "DR(C/D1)" for Red adjustment. When "x" value and "y" value

are not within specification, adjust “DB (C/D1)” or “DR (C/D1)”. Refer to “1. Initial Setting.”

[RF/VIDEO1]----(APL 20%)

Press [3] button to select “COB(C/D1)” for Blue adjustment. Press [1] button to select “COR(C/D1)” for Red adjustment. When “x” value and “y” value are not within specification, adjust “COB (C/D1)” or “COR (C/D1)”. Refer to “1. Initial Setting.”

6. **[VIDEO2]----(APL 80%)**

Press [6] button to select “C-DB(C/D2)” for Blue adjustment. Press [4] button to select “C-DR(C/D2)” for Red adjustment. When “x” value and “y” value are not within specification, adjust “C-DB(C/D2)” or “C-DR(C/D2)”. Refer to “1. Initial Setting.”

[VIDEO2]----(APL 20%)

Press [3] button to select “C-COB(C/D2)” for Blue adjustment. Press [1] button to select “C-COR(C/D2)” for Red adjustment. When “x” value and “y” value are not within specification, adjust “C-COB(C/D2)” or “C-COR(C/D2)”. Refer to “1. Initial Setting.”

7. Turn the power off and on again. (Main power button on the TV unit.)

[VIDEO2]

Press [SETUP] button on the service remote control unit and press [3] on the service remote control (selecting “C-BRT” mode).

3. Make sure that contrast and brightness controls are set to initial position.
 4. Confirm “C” position was beginning to bright.
 5. If “C” position was beginning to bright, no need to adjust.
 6. If “C” position is not available or to be highly brightness, then adjust IIC-BUS data.
- [RF/VIDEO1]: BRT**
[VIDEO2]: C-BRT
7. Turn the power off and on again. (Main power button on the TV unit.)

3. Sub-Brightness Adjustment

Purpose: To get proper brightness.

Symptom of Misadjustment: If Sub-Brightness is incorrect, proper brightness cannot be obtained by adjusting the Brightness Control.

Adj. Point	Input
[SETUP] button	Ant. input, Any channel, SMPTE pattern, [RF/VIDEO1]: CG-931 (KENWOOD), [VIDEO2]: CG-931 (KENWOOD), w/SETUP 7.5IRE
M. EQ.	Spec.
Pattern Generator	See below

Figure

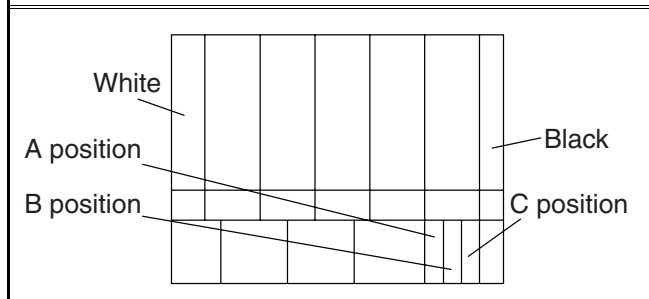

1. Enter the Service mode. Then input above signal.
2. **[RF/VIDEO1]**
Press [SETUP] button on the service remote control unit and press [1] on the service remote control (selecting “BRT” mode).

HOW TO INITIALIZE THE LCD TELEVISION

How to initialize the LCD television:

1. Turn the power on. (Use main power on the TV unit.)
2. To enter the service mode, press the service button on the service remote control unit. (Refer to page 5-1.)
 - To cancel the service mode, press [POWER] button on the remote control.
3. To initialize the LCD television, press [DISPLAY] button on the remote control unit.
4. Confirm "FF" indication on the upper right of the screen.

BLOCK DIAGRAMS

System Control Block Diagram

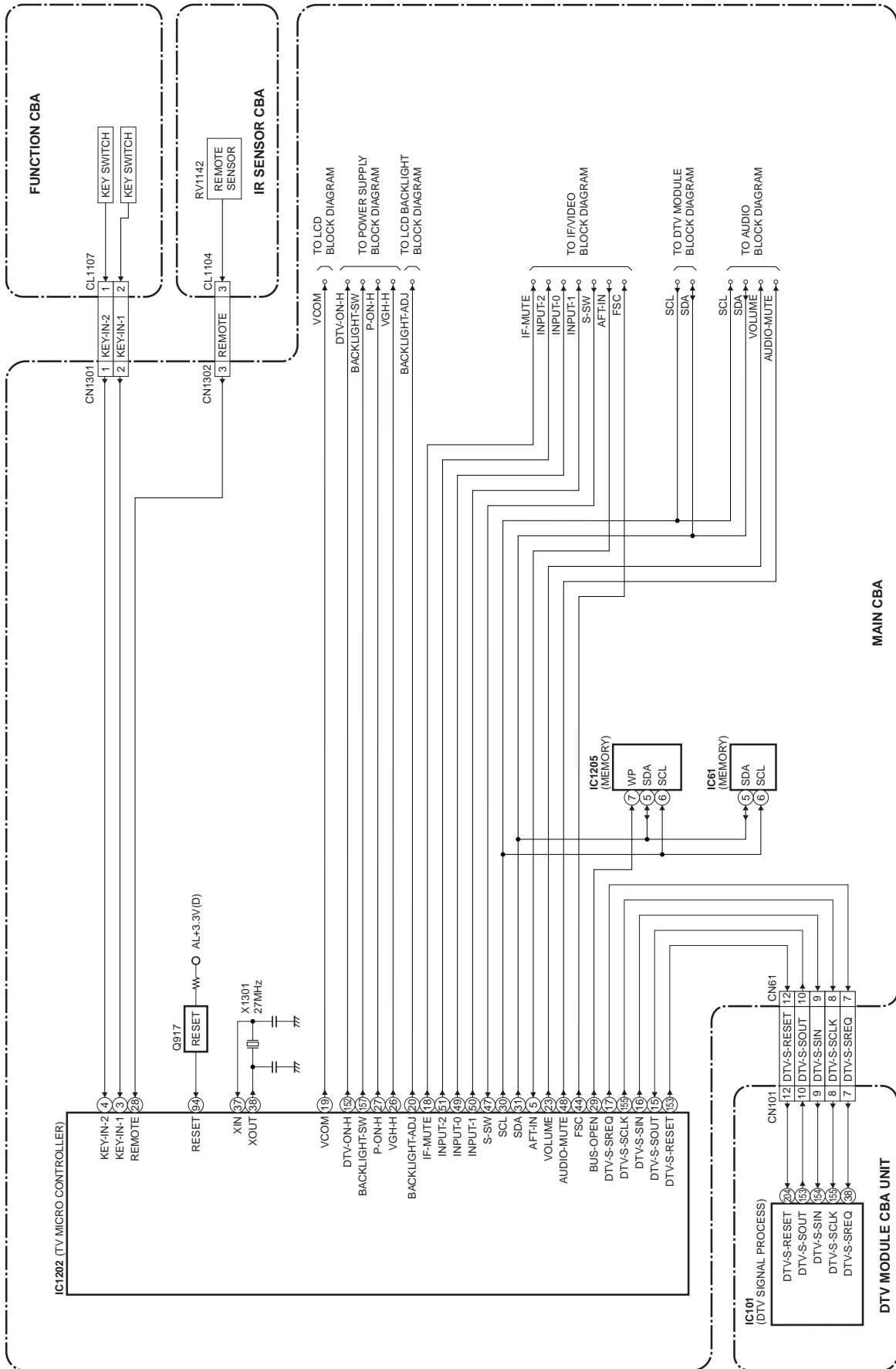

IF/Video Block Diagram

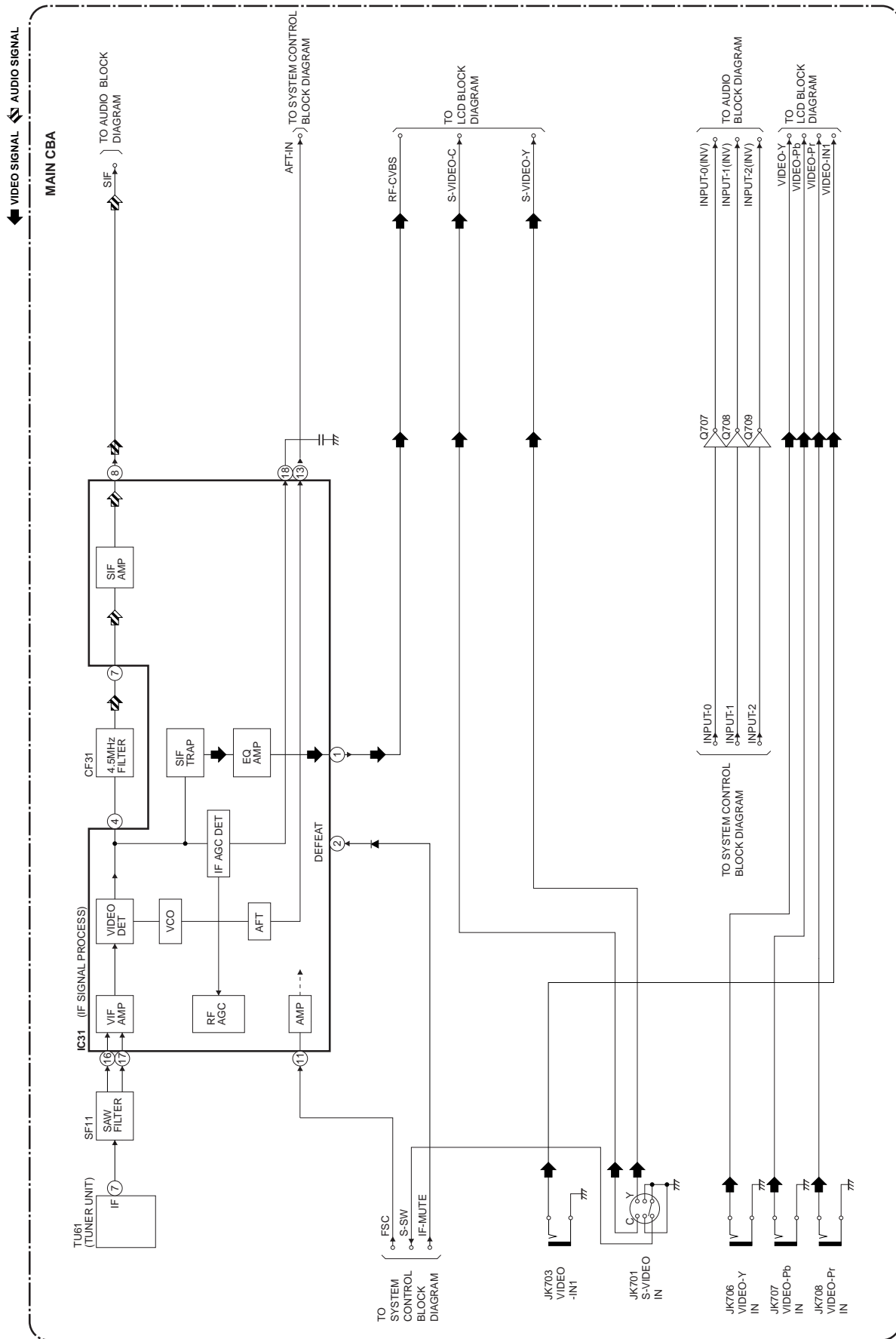

Audio Block Diagram

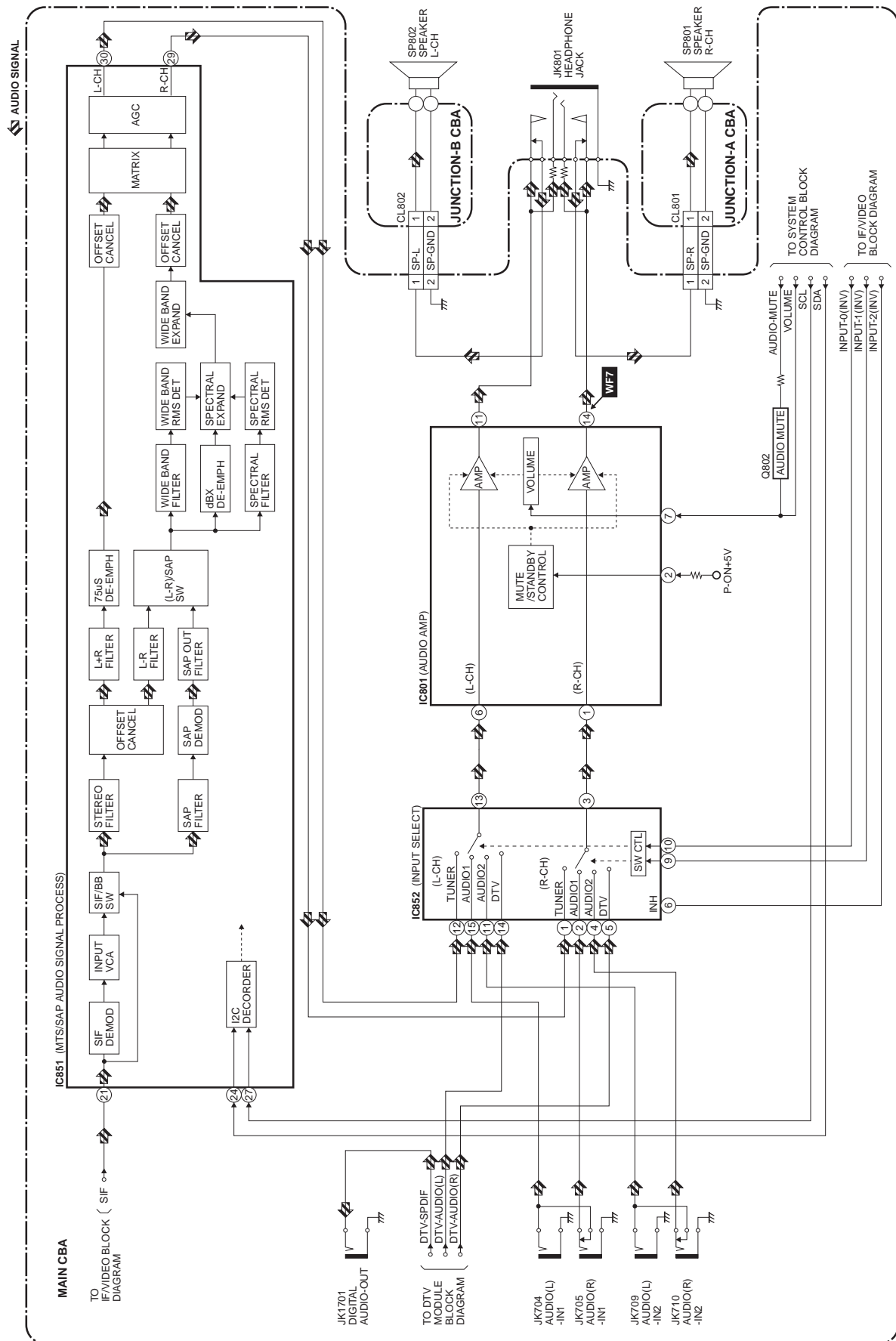

DTV Module Block Diagram

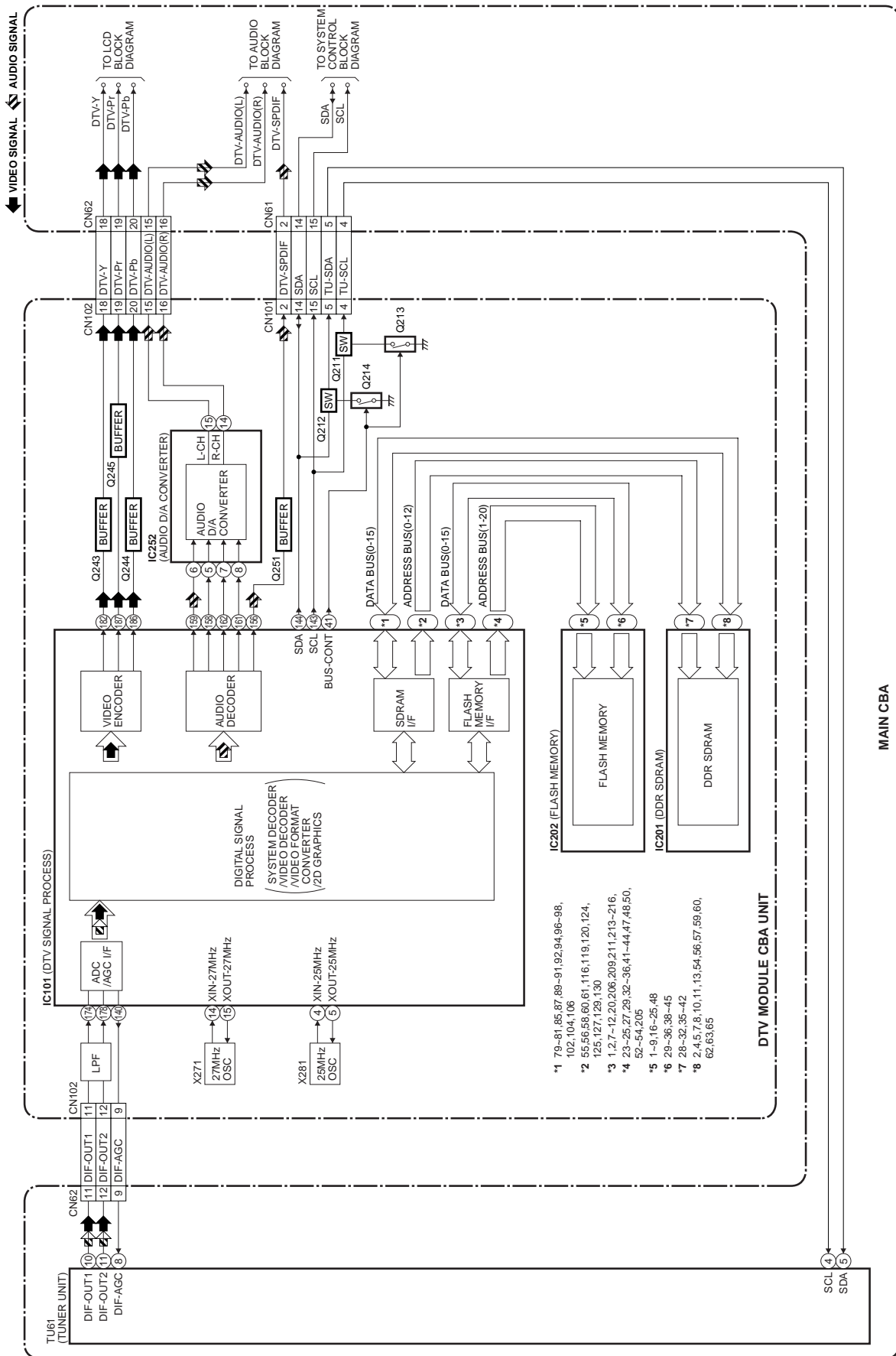

LCD Block Diagram

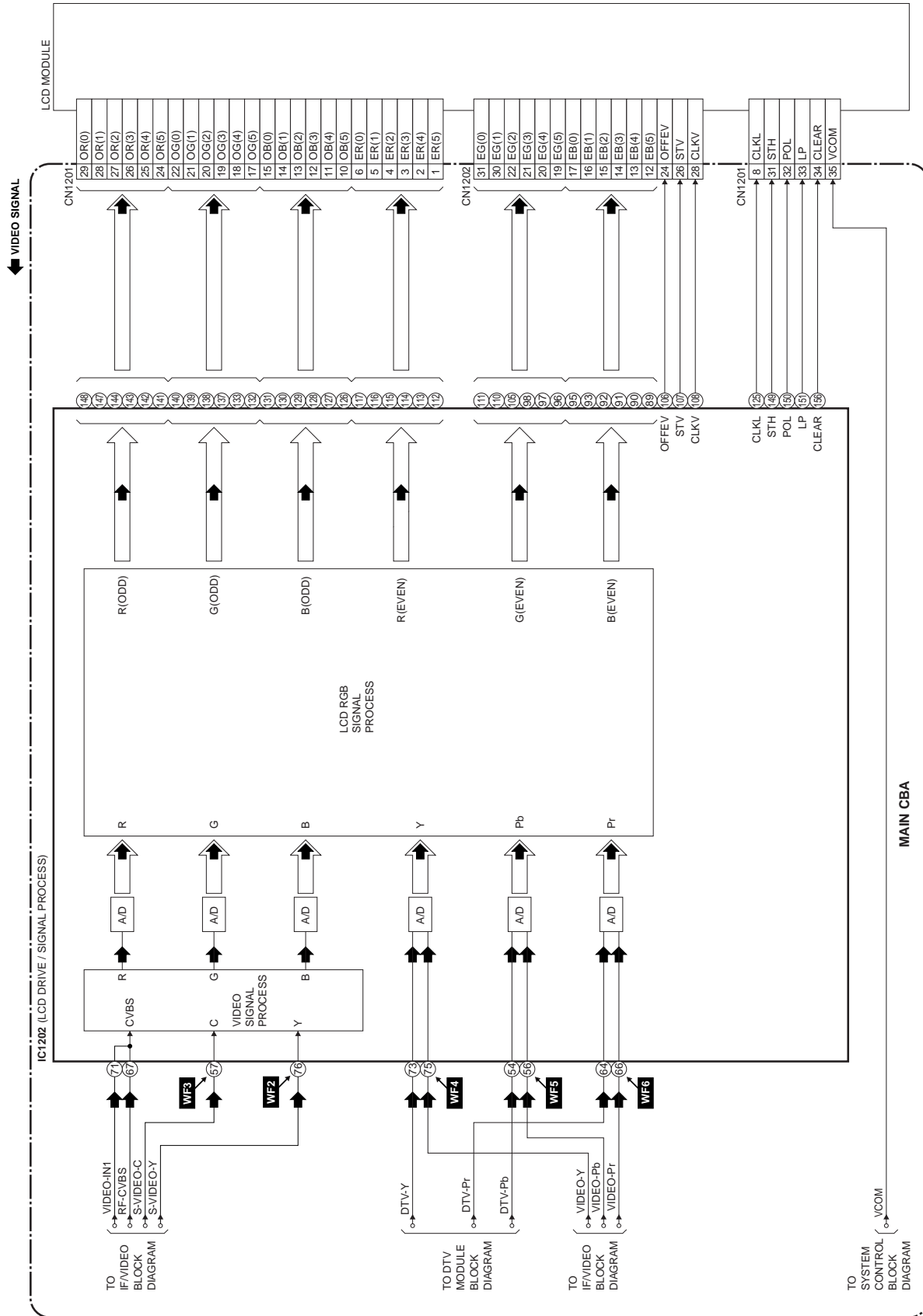

Power Supply Block Diagram

CAUTION !

Fixed voltage (or Auto voltage selectable) power supply circuit is used in this unit. If Main Fuse (F601) is blown, check to see that all components in the power supply circuit are not defective before you connect the AC plug to the AC power supply. Otherwise it may cause some components in the power supply circuit to fail.



CAUTION ! : For continued protection against risk of fire, replace only with same type 4 A, 125V fuse.
ATTENTION : Utiliser un fusible de même type de 4A, 125V.

NOTE:

The voltage for parts in hot circuit is measured using hot GND as a common terminal.

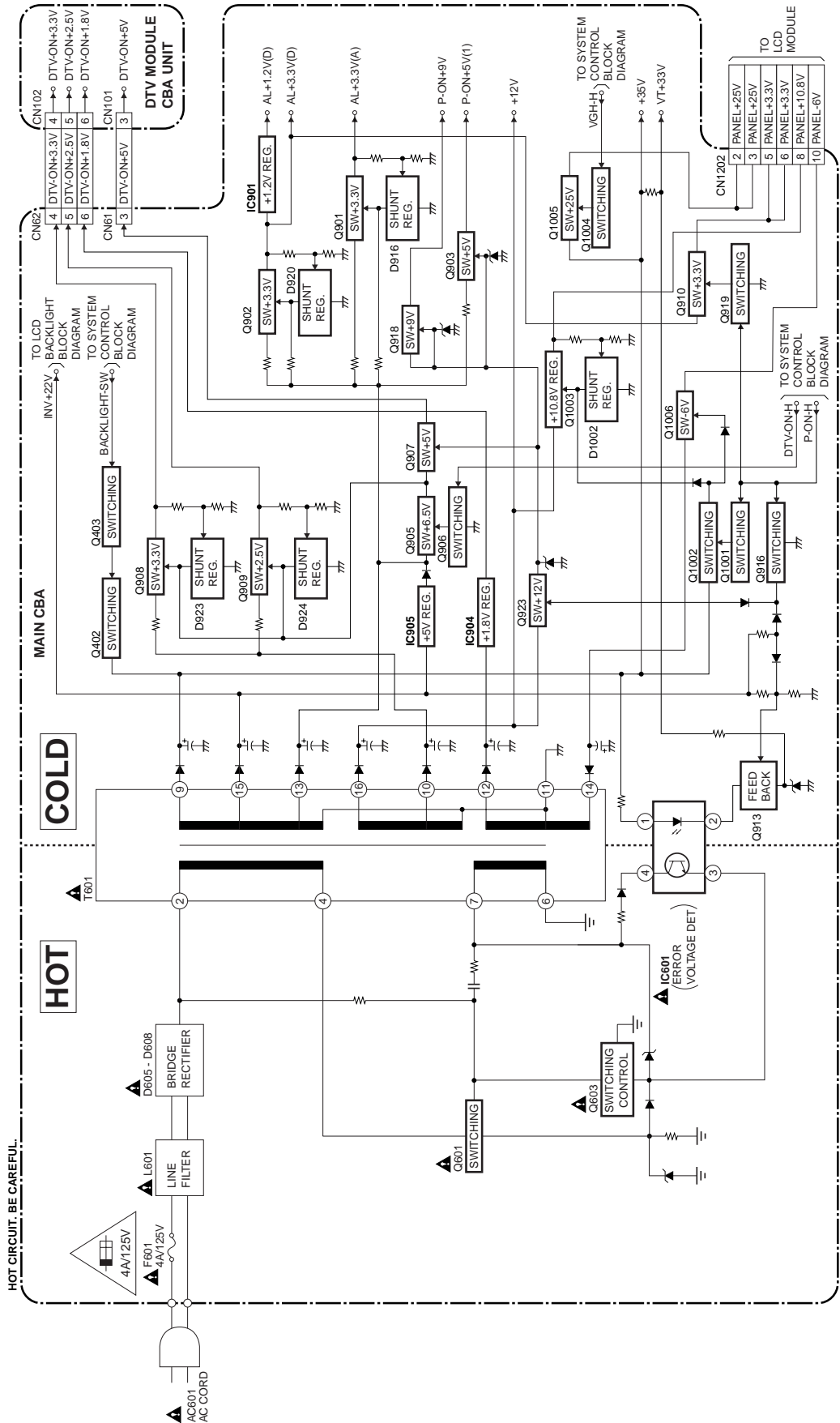

LCD Backlight Block Diagram

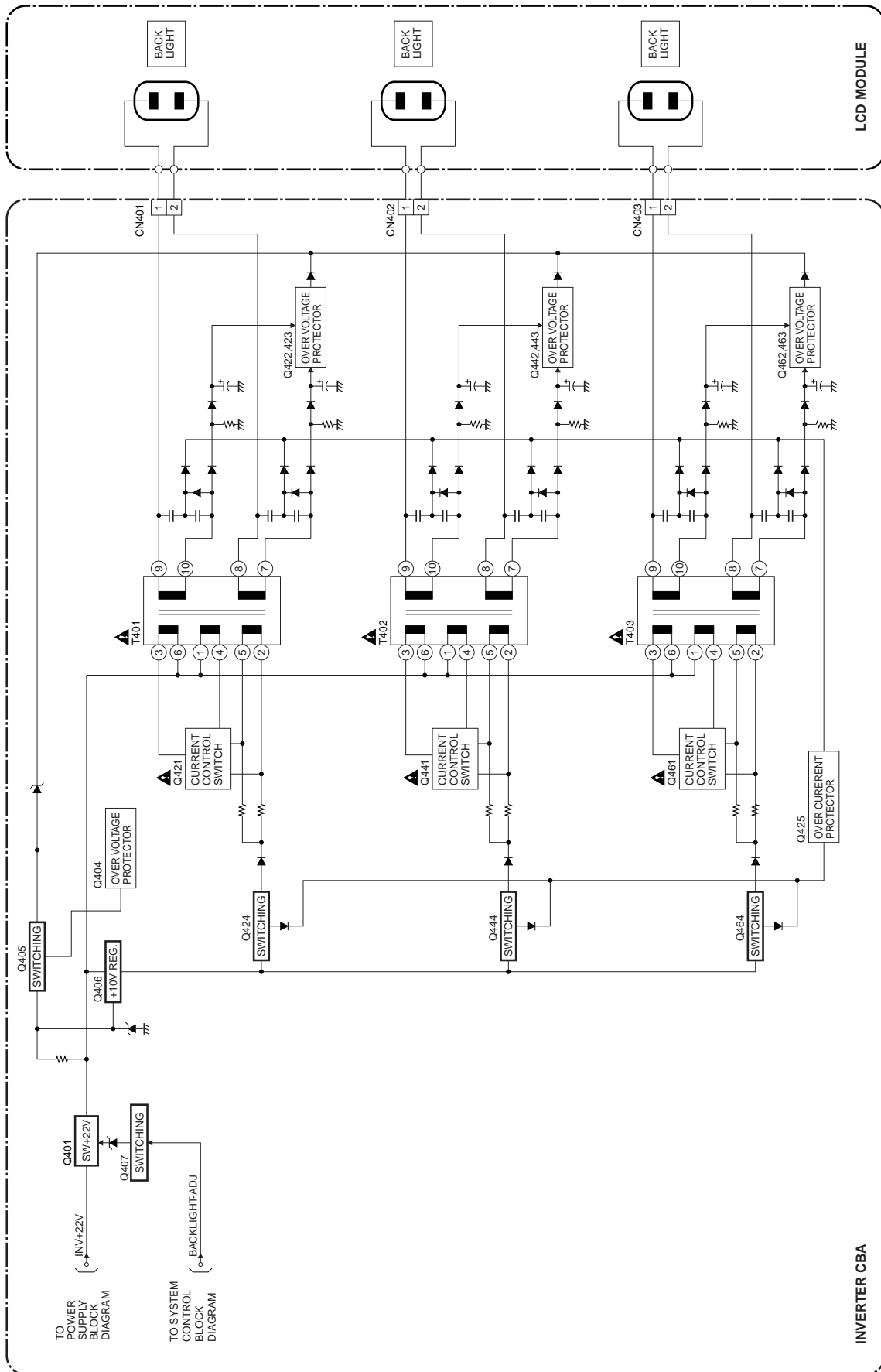

SCHEMATIC DIAGRAMS / CBA'S AND TEST POINTS

Standard Notes

Many electrical and mechanical parts in this chassis have special characteristics. These characteristics often pass unnoticed and the protection afforded by them cannot necessarily be obtained by using replacement components rated for higher voltage, wattage, etc. Replacement parts that have these special safety characteristics are identified in this manual and its supplements; electrical components having such features are identified by the mark “▲” in the schematic diagram and the parts list. Before replacing any of these components, read the parts list in this manual carefully. The use of substitute replacement parts that do not have the same safety characteristics as specified in the parts list may create shock, fire, or other hazards.

Notes:

1. Do not use the part number shown on these drawings for ordering. The correct part number is shown in the parts list, and may be slightly different or amended since these drawings were prepared.
2. All resistance values are indicated in ohms ($K = 10^3$, $M = 10^6$).
3. Resistor wattages are 1/4W or 1/6W unless otherwise specified.
4. All capacitance values are indicated in μF ($P = 10^{-6} \mu F$).
5. All voltages are DC voltages unless otherwise specified.

Note of Capacitors:

ML --- Mylar Cap. PP --- Metallized Film Cap. SC --- Semiconductor Cap. L --- Low Leakage type

Temperature Characteristics of Capacitors are noted with the following:

B --- $\pm 10\%$ CH --- 0 ± 60 ppm/ $^{\circ}C$ CSL --- $+350 \sim 1000$ ppm/ $^{\circ}C$

Tolerance of Capacitors are noted with the following:

Z --- $+80 \sim -20\%$

Note of Resistors:

CEM --- Cement Res. MTL --- Metal Res. F --- Fuse Res.

Capacitors and transistors are represented by the following symbols.

CBA Symbols

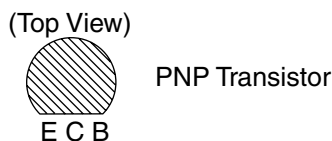
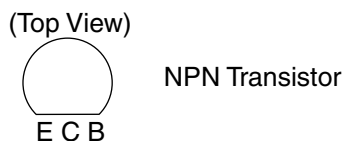
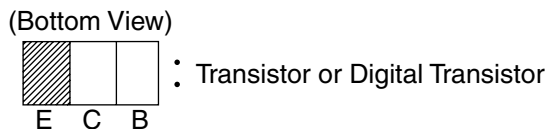
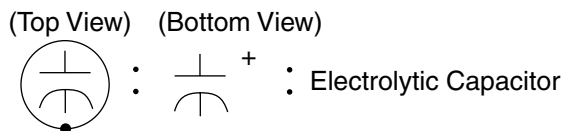

Schematic Diagram Symbols

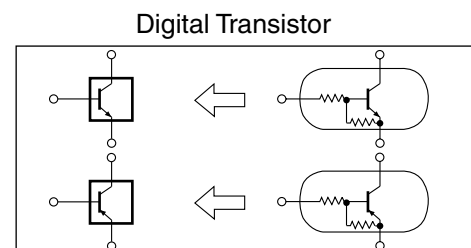

LIST OF CAUTION, NOTES, AND SYMBOLS USED IN THE SCHEMATIC DIAGRAMS ON THE FOLLOWING PAGES:

1. CAUTION:

CAUTION: FOR CONTINUED PROTECTION AGAINST RISK OF FIRE, REPLACE ONLY WITH SAME TYPE_A,_V FUSE.

ATTENTION: UTILISER UN FUSIBLE DE RECHANGE DE MÊME TYPE DE_A,_V.

2. CAUTION:

Fixed Voltage (or Auto voltage selectable) power supply circuit is used in this unit.

If Main Fuse (F601) is blown, first check to see that all components in the power supply circuit are not defective before you connect the AC plug to the AC power supply. Otherwise it may cause some components in the power supply circuit to fail.

3. Note:

- Do not use the part number shown on the drawings for ordering. The correct part number is shown in the parts list, and may be slightly different or amended since the drawings were prepared.
- To maintain original function and reliability of repaired units, use only original replacement parts which are listed with their part numbers in the parts list section of the service manual.

4. Voltage indications on the schematics are as shown below:

Plug the TV power cord into a standard AC outlet.:

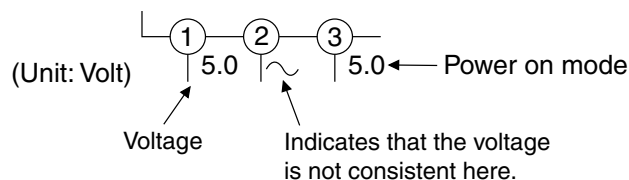

5. How to read converged lines

1-D3
 ↑ Distinction Area
 ↑ Line Number
 (1 to 3 digits)

Examples:

- "1-D3" means that line number "1" goes to the line number "1" of the area "D3".
- "1-B1" means that line number "1" goes to the line number "1" of the area "B1".

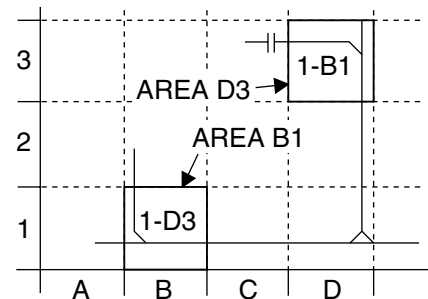

6. Test Point Information

- ⊕ : Indicates a test point with a jumper wire across a hole in the PCB.
- : Used to indicate a test point with a component lead on foil side.
- ⊗ : Used to indicate a test point with no test pin.
- : Used to indicate a test point with a test pin.

Main 1/5 Schematic Diagram

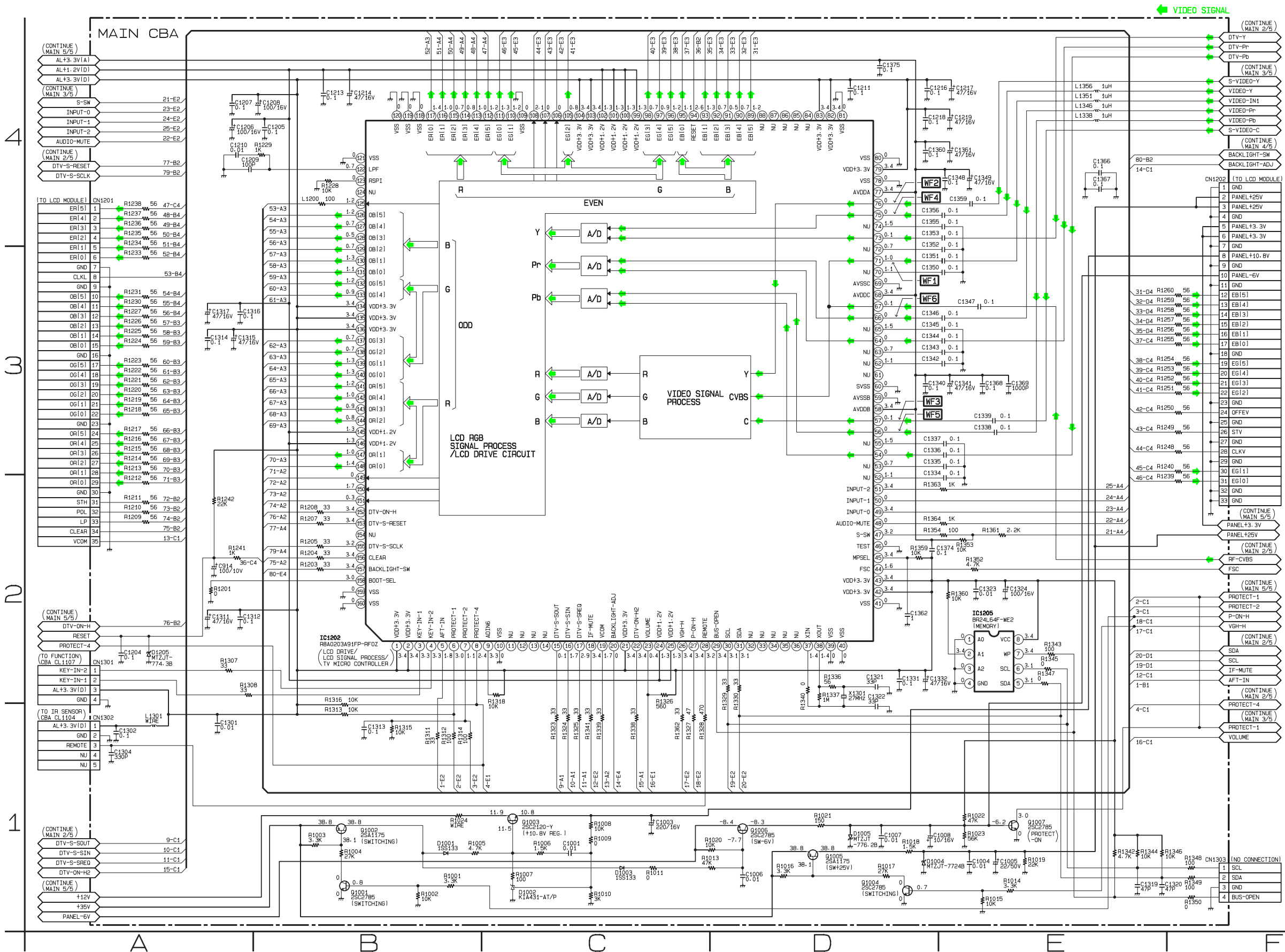

VOLTAGE CHART

CN1201

Pin No.	Voltage
1	1.2
2	1.0
3	0.8
4	0.7
5	1.0
6	1.4
7	0
8	1.2
9	0
10	1.2
11	0.7
12	0.5
13	0.7
14	1.3
15	1.1
16	0
17	1.2
18	0.9
19	0.7
20	0.7
21	1.3
22	1.3
23	0
24	1.2
25	1.0
26	0.9
27	0.8
28	1.0
29	1.4
30	0
31	0
32	1.7
33	0.3
34	3.4
35	1.7

CN1202

Pin No.	Voltage
1	0
2	24.4
3	24.4
4	0
5	3.3
6	3.3
7	0
8	10.8
9	0
10	-6.2
11	0
12	1.2
13	0.7
14	0.5
15	0.7
16	1.3
17	1.1
18	0
19	1.2
20	0.9
21	0.7
22	0.8
23	0
24	0
25	0
26	0
27	0
28	2.1
29	0
30	1.3
31	1.3
32	0
33	0

Main 2/5 Schematic Diagram

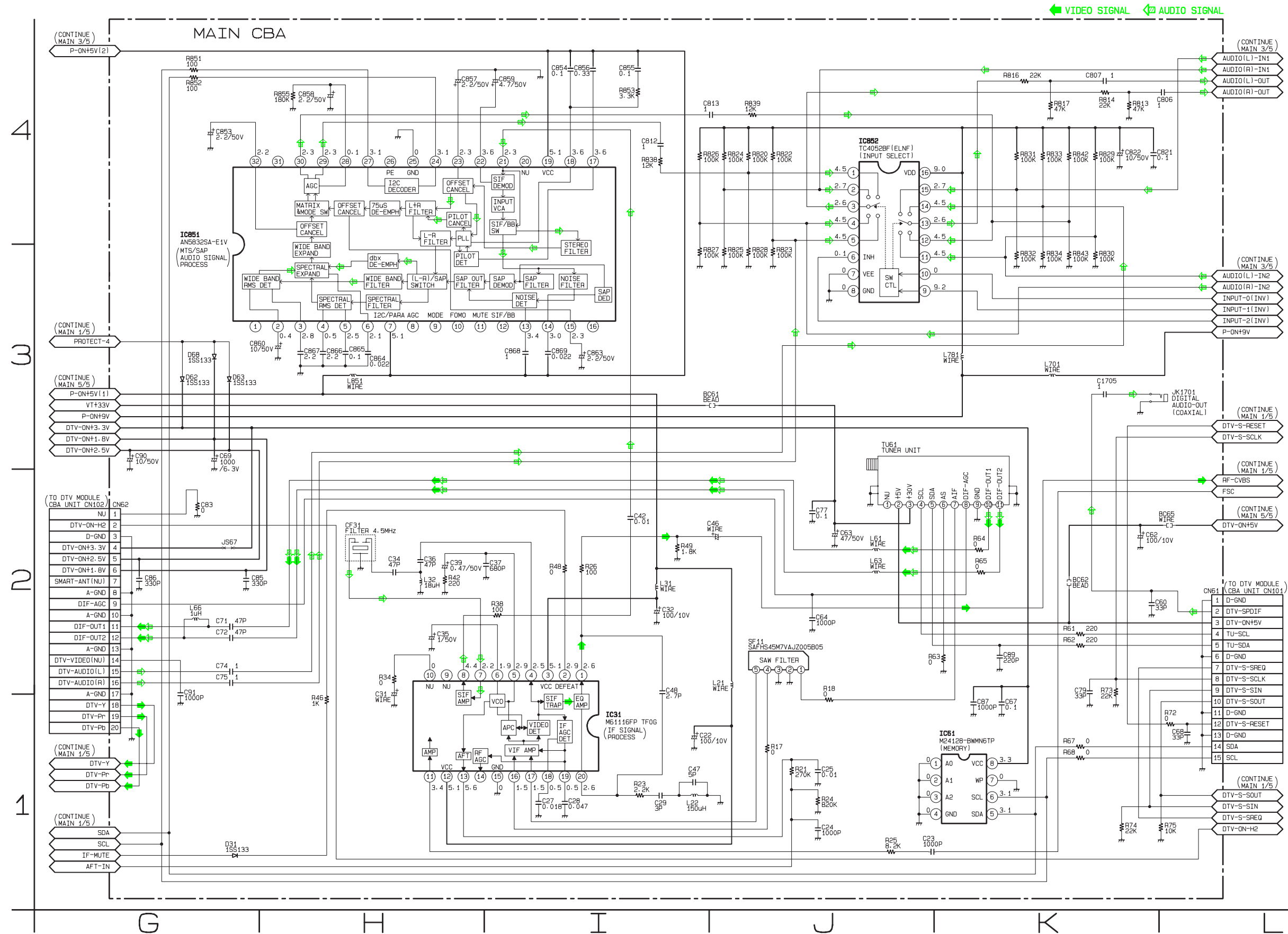

VOLTAGE CHART

Pin No.	Voltage
1	0
2	1.1
3	5.2
4	3.1
5	3.2
6	0
7	2.9
8	3.2
9	1.7
10	0.1
11	0
12	3.4
13	0
14	3.1
15	3.1

Pin No.	Voltage
1	---
2	3.3
3	0
4	3.4
5	2.6
6	1.9
7	---
8	0
9	0
10	0
11	0
12	0
13	0
14	---
15	2.6
16	2.6
17	0
18	~
19	~
20	~

Main 3/5, Junction-A & Junction-B Schematic Diagram

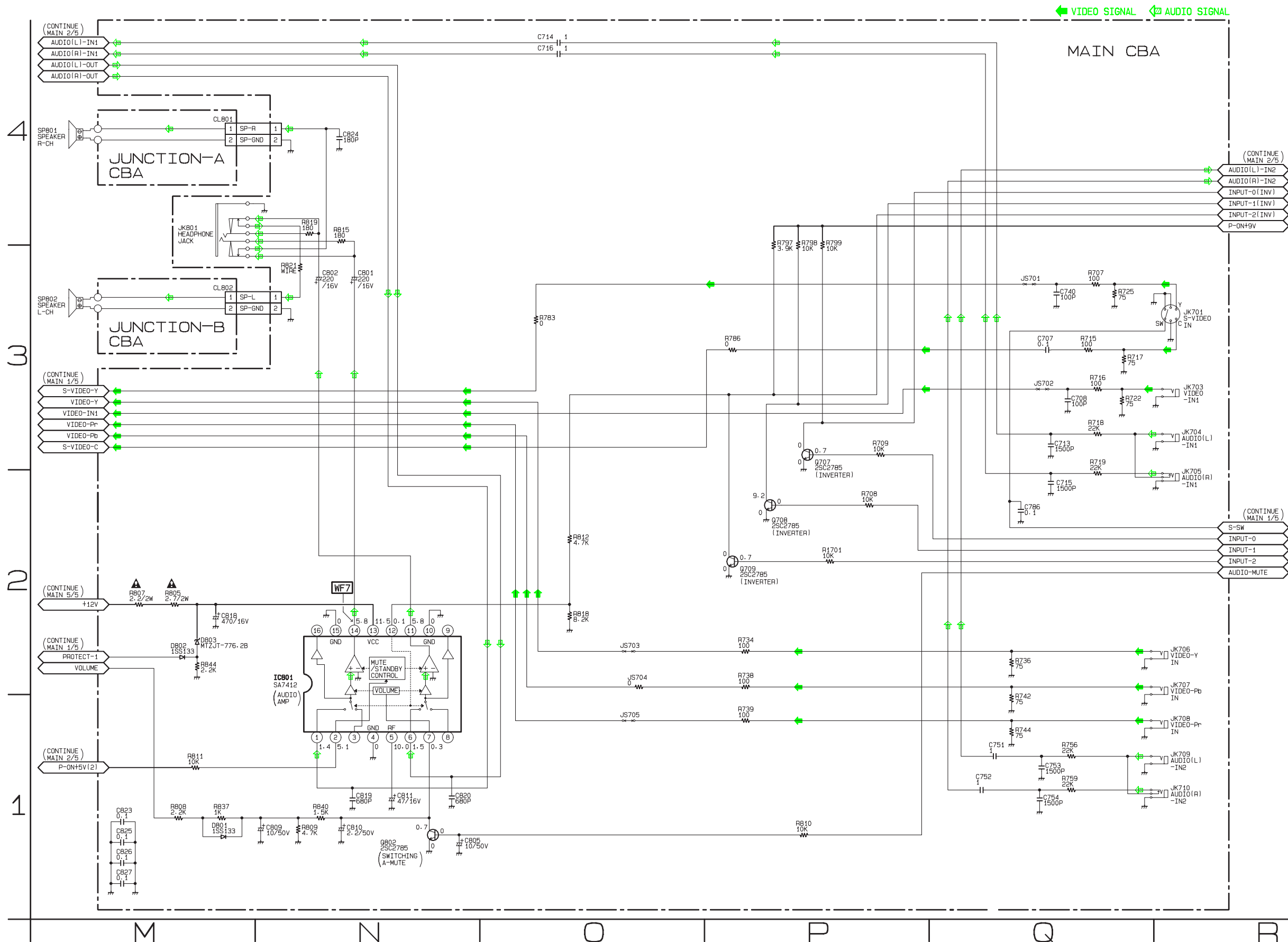

Main 4/5 Schematic Diagram

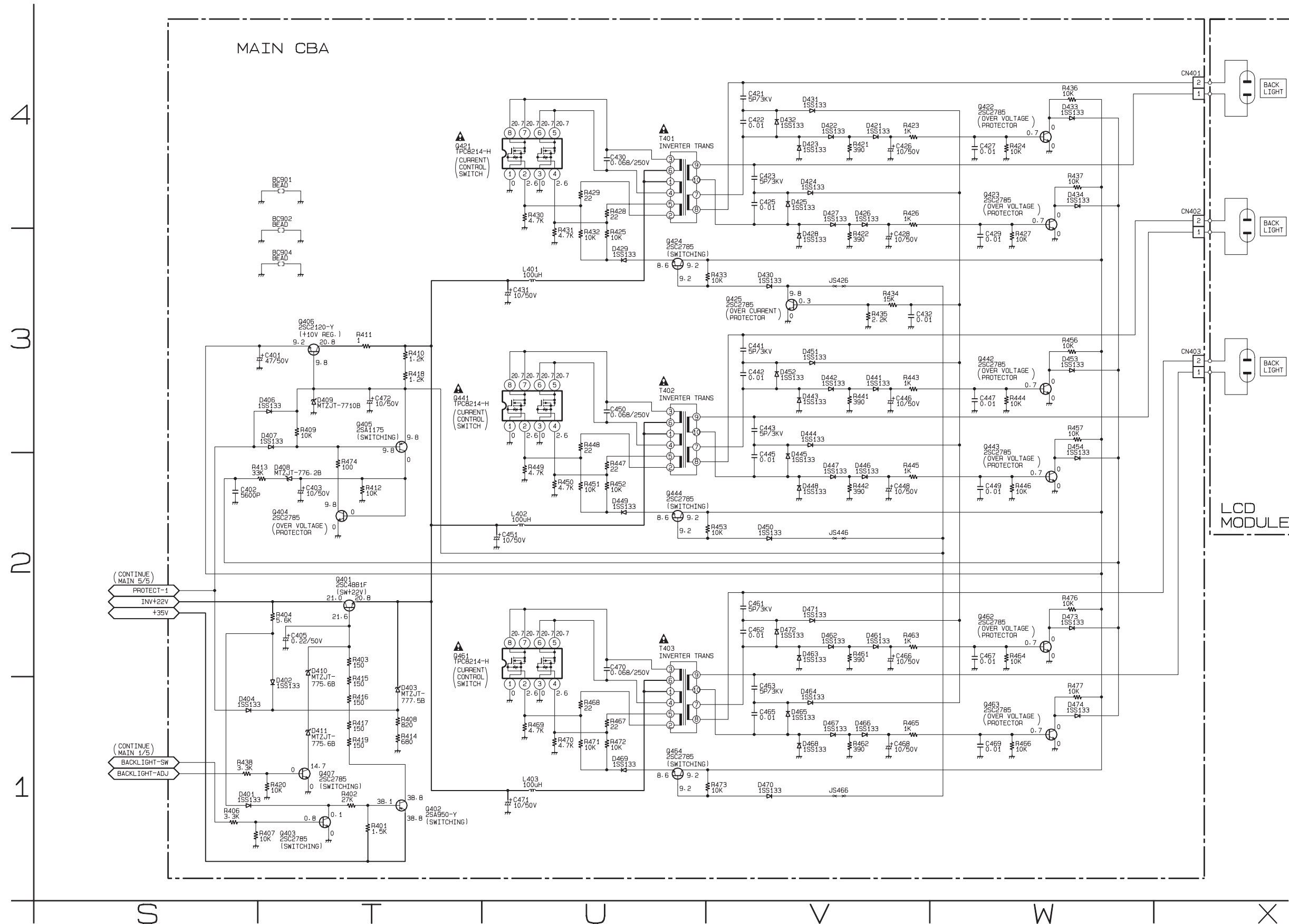

Main 5/5 Schematic Diagram

CAUTION !

Fixed voltage (or Auto voltage selectable) power supply circuit is used in this unit.
If Main Fuse (F601) is blown, check to see that all components in the power supply circuit are not defective before you connect the AC plug to the AC power supply.
Otherwise it may cause some components in the power supply circuit to fail.

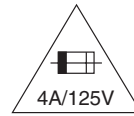

CAUTION ! : For continued protection against risk of fire, replace only with same type 4 A, 125V fuse.
ATTENTION : Utiliser un fusible de rechange de même type de 4A, 125V.

NOTE:

The voltage for parts in hot circuit is measured using hot GND as a common terminal.

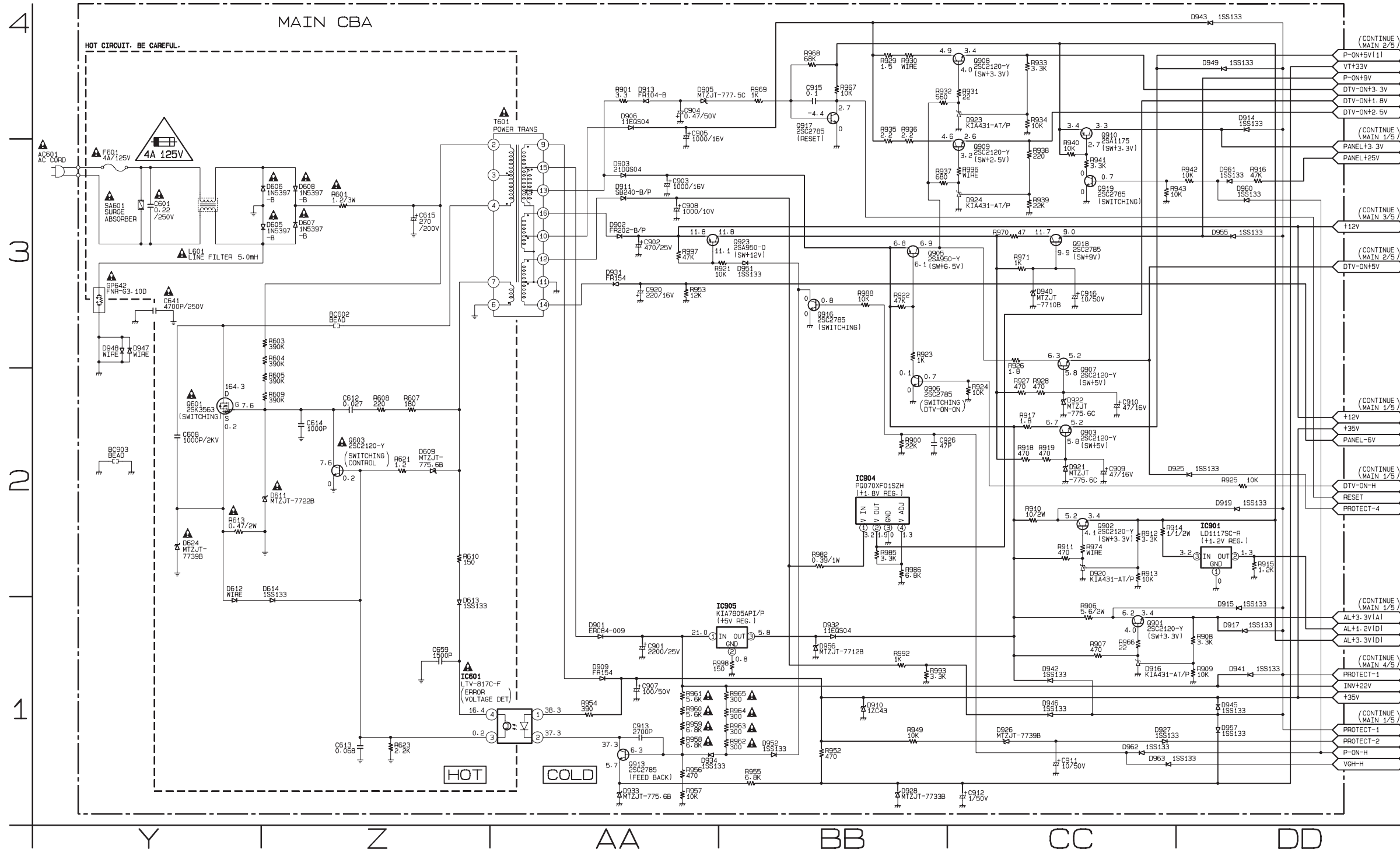

Function Schematic Diagram

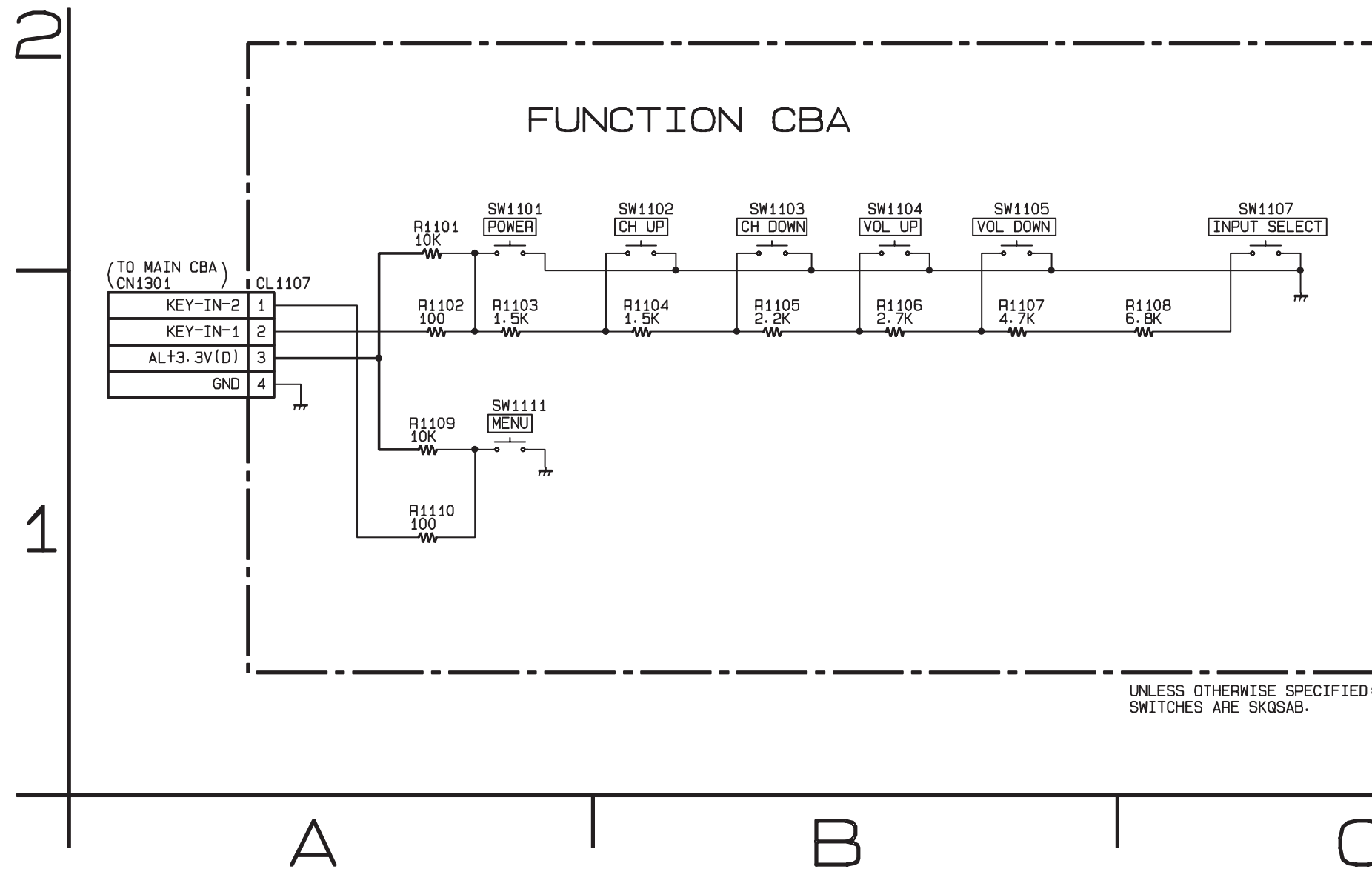

IR Sensor Schematic Diagram

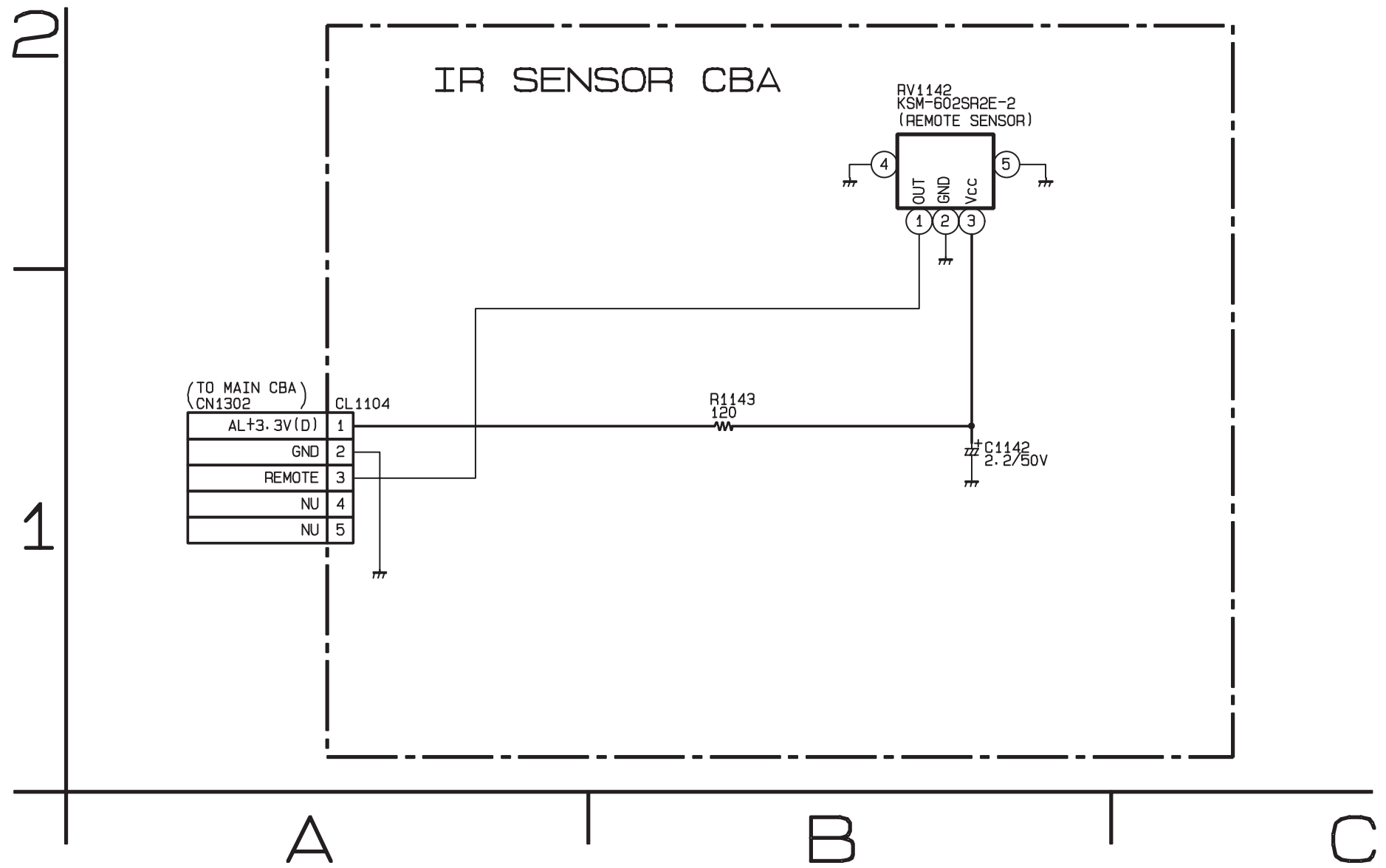

Main CBA Top View

CAUTION !

Fixed voltage (or Auto voltage selectable) power supply circuit is used in this unit. If Main Fuse (F601) is blown, check to see that all components in the power supply circuit are not defective before you connect the AC plug to the AC power supply. Otherwise it may cause some components in the power supply circuit to fail.

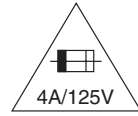

CAUTION ! : For continued protection against risk of fire, replace only with same type 4 A, 125V fuse.
ATTENTION : Utiliser un fusible de rechange de même type de 4A, 125V.

NOTE:
 The voltage for parts in hot circuit is measured using hot GND as a common terminal.

Because a hot chassis ground is present in the power supply circuit, an isolation transformer must be used. Also, in order to have the ability to increase the input slowly, when troubleshooting this type power supply circuit, a variable isolation transformer is required.

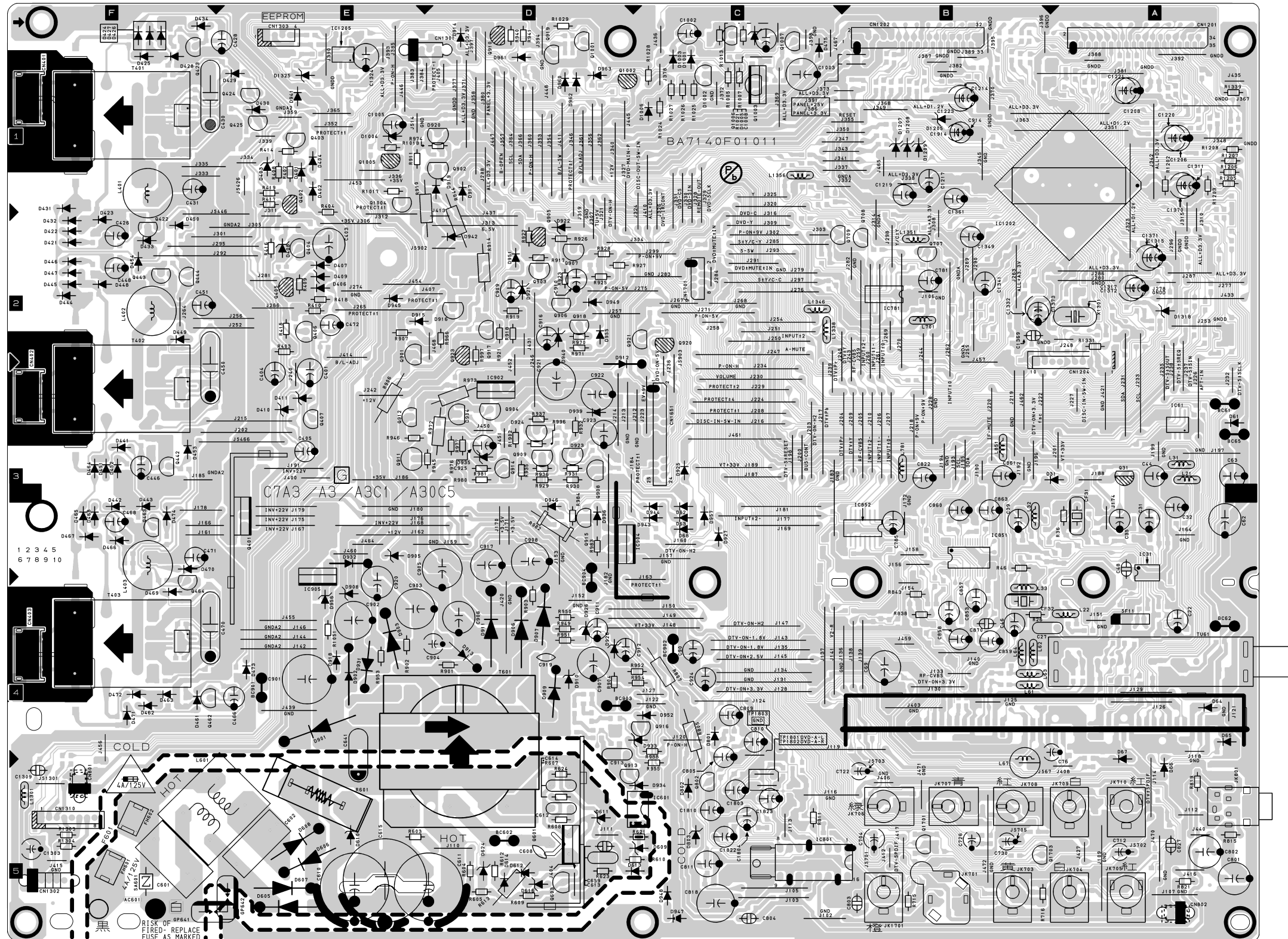

Main CBA Bottom View

CAUTION !

Fixed voltage (or Auto voltage selectable) power supply circuit is used in this unit.
If Main Fuse (F601) is blown, check to see that all components in the power supply circuit are not defective before you connect the AC plug to the AC power supply.
Otherwise it may cause some components in the power supply circuit to fail.

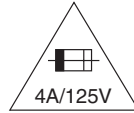

CAUTION ! : For continued protection against risk of fire, replace only with same type 4 A, 125V.

ATTENTION : Utiliser un fusible de rechange de même type de 4A, 125V.

NOTE:

The voltage for parts in hot circuit is measured using hot GND as a common terminal.

Because a hot chassis ground is present in the power supply circuit, an isolation transformer must be used. Also, in order to have the ability to increase the input slowly, when troubleshooting this type power supply circuit, a variable isolation transformer is required.

- WF4**
PIN 75 OF
IC1202
- WF2**
PIN 76 OF
IC1202
- WF5**
PIN 56 OF
IC1202
- WF3**
PIN 57 OF
IC1202
- WF6**
PIN 66 OF
IC1202
- WF1**
PIN 71 OF
IC1202

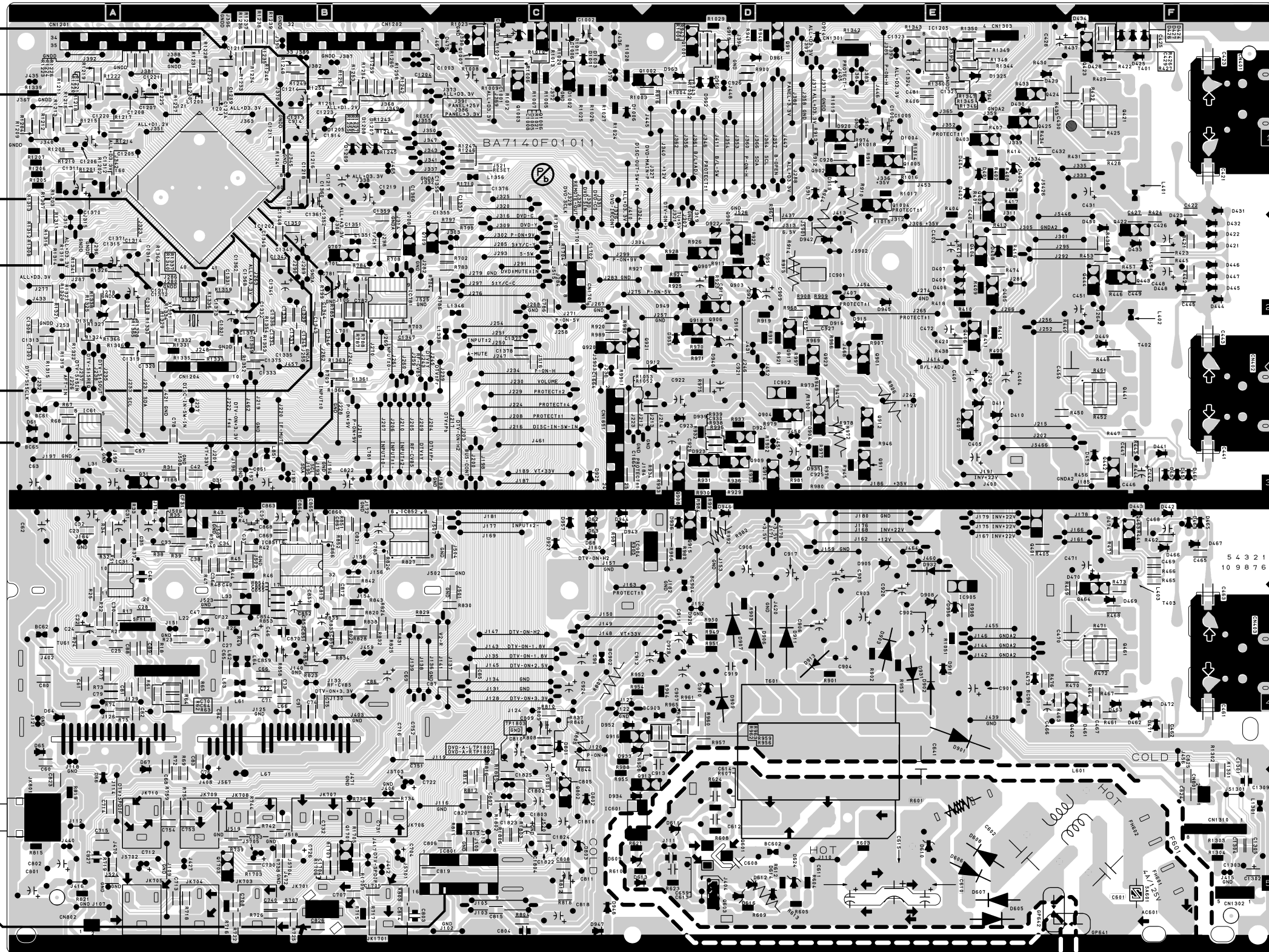

- WF7**
PIN 14 OF
IC801

Function CBA Top View

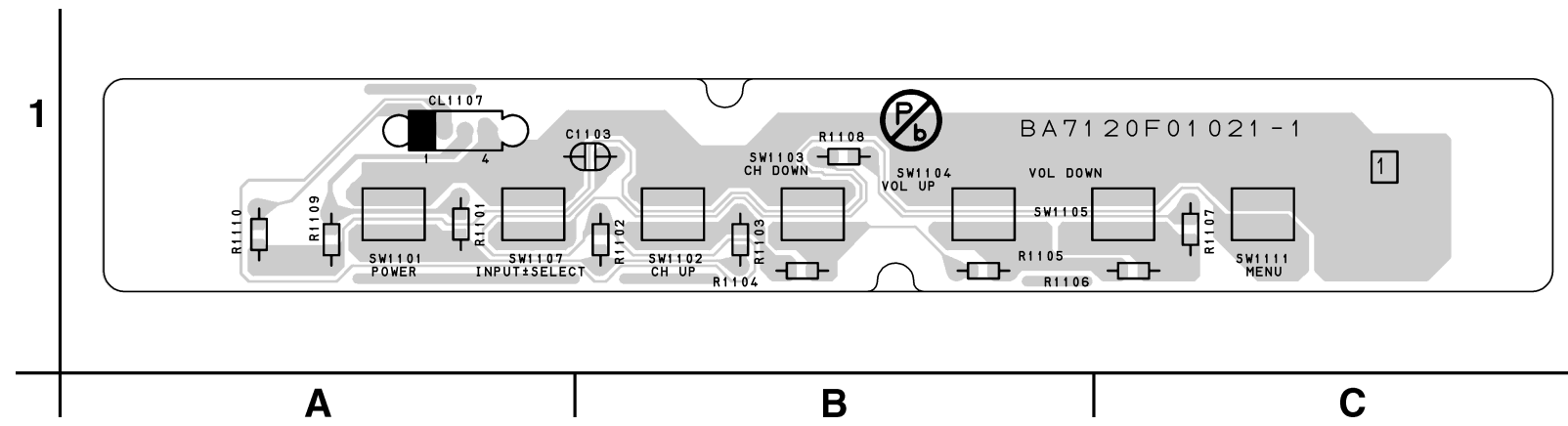

IR Sensor CBA Top View

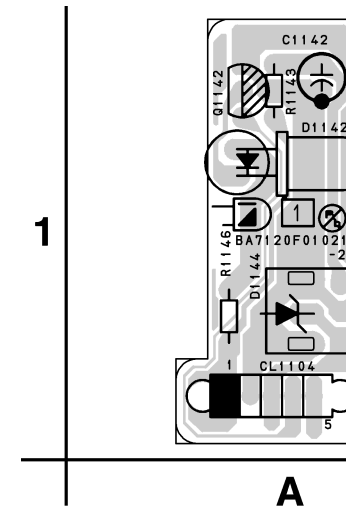

IR Sensor CBA Bottom View

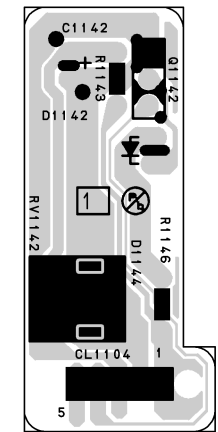

BA7120F01021-2

Function CBA Bottom View

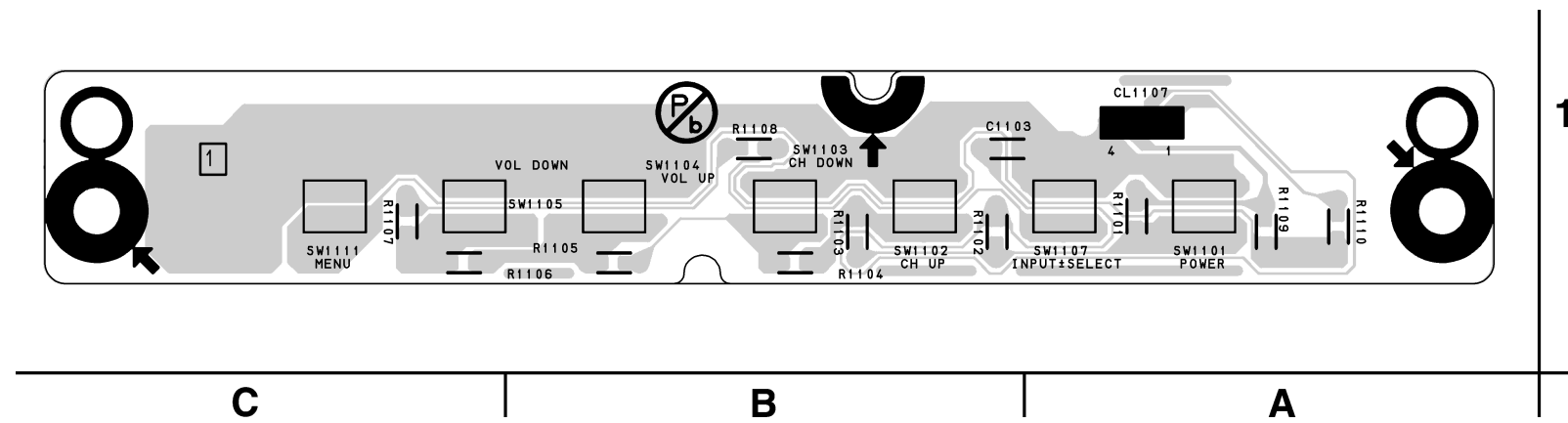

BA7120F01021-1

Junction-A CBA Top & Bottom View

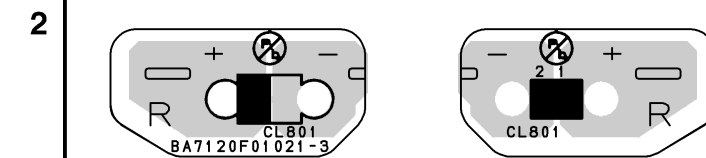

BA7120F01021-3

Junction-B CBA Top & Bottom View

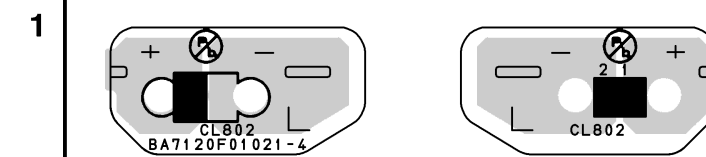

BA7120F01021-4

WAVEFORMS

WF1 ~ WF7 = Waveforms to be observed at
Waveform check points.
(Shown in Schematic Diagram.)

Input: NTSC Color Bar Signal (with 1kHz Audio Signal)

WF1 Pin 71 of IC1202

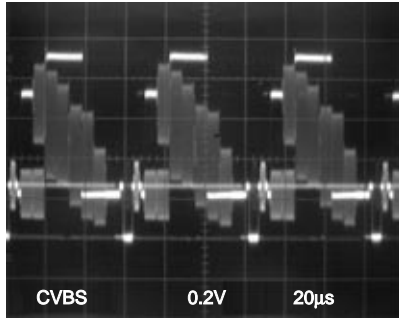

WF5 Pin 56 of IC1202

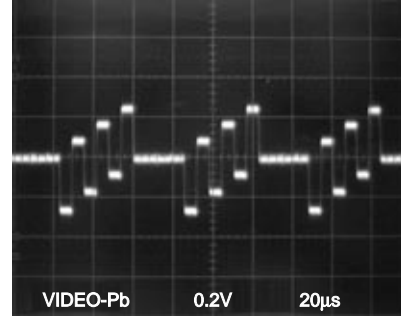

WF2 Pin 76 of IC1202

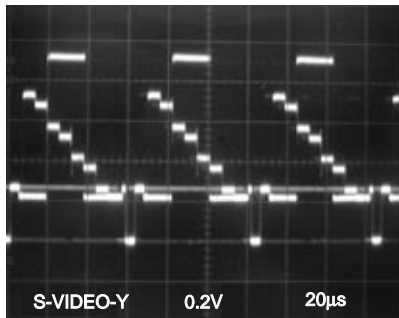

WF6 Pin 66 of IC1202

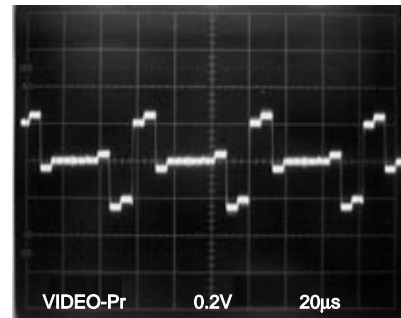

WF3 Pin 57 of IC1202

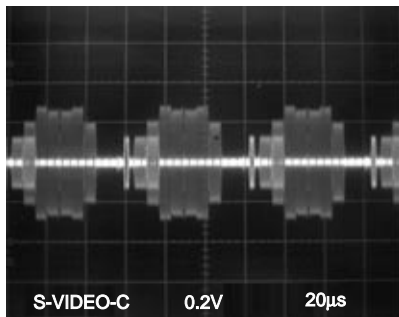

WF7 Pin 14 of IC801

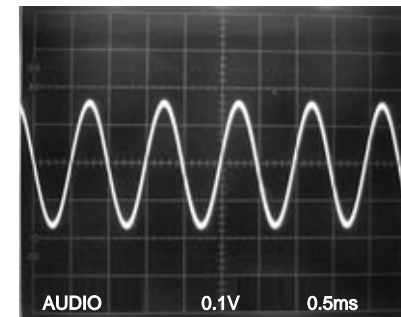

WF4 Pin 75 of IC1202

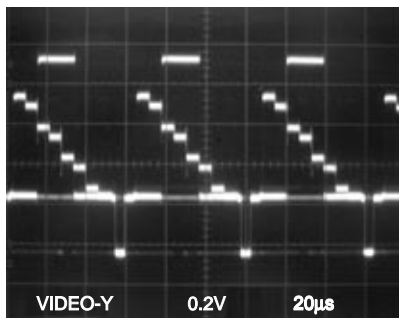

WIRING DIAGRAM

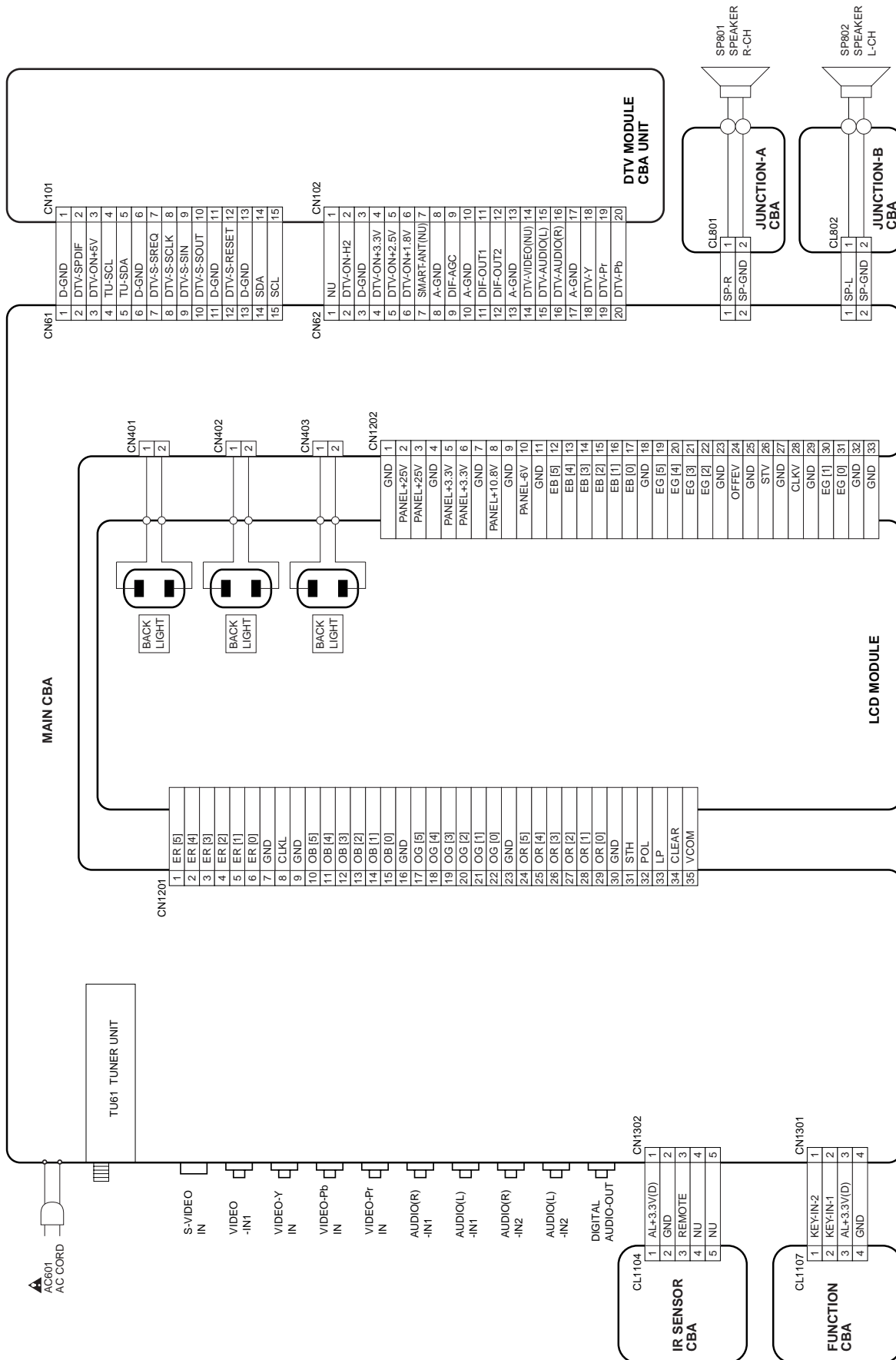

IC PIN FUNCTION DESCRIPTIONS

IC1202 (LCD Drive / LCD Signal Process / TV Micro Controller)

Pin No.	Signal Name	Function
1	VDD+3.3V	+3.3V VDD
2	VDD+3.3V	+3.3V VDD
3	KEY-IN-1	Key Input 1
4	KEY-IN-2	Key Input 2
5	AFT-IN	AFT Voltage Input
6	PROTECT-1	Power Supply Protection 1
7	PROTECT-2	Power Supply Protection 2
8	PROTECT-4	Power Supply Protection 4
9	ADIN6	Reference Terminal
10	VSS	GND
11	NU	Not Used
12	NU	Not Used
13	NU	Not Used
14	NU	Not Used
15	DTV-S-SOUT	DTV Serial Data Out
16	DTV-S-SIN	DTV Serial Data In
17	DTV-S-SREQ	DTV Serial Request
18	IF-MUTE	IF Mute Signal Output
19	VCOM	VCOM
20	BACKLIGHT-ADJ	Inverter Control Signal Output
21	VDD+3.3V	+3.3V VDD
22	DTV-ON-H2	DTV On Signal 2 at High
23	VOLUME	Volume Control Signal Output
24	VDD+1.2V	+1.2V VDD
25	VDD+1.2V	+1.2V VDD
26	VGH-H	VGH Signal at High
27	P-ON-H	Power On Signal at High
28	REMOTE	Remote Control Signal Input
29	BUS-OPEN	Chip select
30	SCL	Serial Clock
31	SDA	Serial Data
32	NU	Not Used
33	NU	Not Used
34	NU	Not Used
35	NU	Not Used
36	NU	Not Used
37	XIN	Crystal Oscillation Input (27MHz)

Pin No.	Signal Name	Function
38	XOUT	Crystal Oscillation Output (27MHz)
39	VSS	GND
40	VSS	GND
41	VSS	GND
42	VDD+3.3V	+3.3V VDD
43	VDD+3.3V	+3.3V VDD
44	FSC	Clock Output
45	MPSEL	MP Select
46	TEST	GND
47	S-SW	Detecting S-VIDEO Jack Connection
48	AUDIO-MUTE	Audio Mute Signal Output
49	INPUT-0	Input Select 0 Signal Output
50	INPUT-1	Input Select 1 Signal Output
51	INPUT-2	Input Select 2 Signal Output
52	NU	Not Used
53	NU	Not Used
54	DTV-Pb	DTV Pb Signal Input
55	NU	Not Used
56	VIDEO-Pb	Component Video Pb Signal Input
57	S-VIDEO-C	Chrominance Signal Input
58	AVDDB	+3.3V VDD
59	AVSSB	GND
60	SVSS	GND
61	NU	Not Used
62	NU	Not Used
63	NU	Not Used
64	DTV-Pr	DTV Pr Signal Input
65	NU	Not Used
66	VIDEO-Pr	Component Video Pr Signal Input
67	RF-CVBS	Composite Video Signal Input
68	AVDDC	+3.3V VDD
69	AVSSC	GND
70	NU	Not Used
71	VIDEO-IN1	Composite Video Signal Input
72	NU	Not Used
73	DTV-Y	DTV Y Signal Input
74	NU	Not Used
75	VIDEO-Y	Component Video Y Signal Input

Pin No.	Signal Name	Function
76	S-VIDEO-Y	Luminance Signal Input
77	AVDDA	+3.3V VDD
78	VSS	GND
79	VDD+3.3V	+3.3V VDD
80	VSS	GND
81	VSS	GND
82	VDD+3.3V	+3.3V VDD
83	VDD+3.3V	+3.3V VDD
84	NU	Not Used
85	NU	Not Used
86	NU	Not Used
87	NU	Not Used
88	NU	Not Used
89	EB[5]	Pixel Data Output (EB)
90	EB[4]	Pixel Data Output (EB)
91	EB[3]	Pixel Data Output (EB)
92	EB[2]	Pixel Data Output (EB)
93	EB[1]	Pixel Data Output (EB)
94	RESET	Reset Output
95	EB[0]	Pixel Data Output (EB)
96	EG[5]	Pixel Data Output (EG)
97	EG[4]	Pixel Data Output (EG)
98	EG[3]	Pixel Data Output (EG)
99	VDD+1.2V	+1.2V VDD
100	VDD+1.2V	+1.2V VDD
101	VDD+1.2V	+1.2V VDD
102	VDD+1.2V	+1.2V VDD
103	VDD+3.3V	+3.3V VDD
104	VDD+3.3V	+3.3V VDD
105	EG[2]	Pixel Data Output (EG)
106	OFFEV	Enable Signal
107	STV	Start Pulse Signal
108	CLKV	Shift Clock Signal
109	VSS	GND
110	EG[1]	Pixel Data Output (EG)
111	EG[0]	Pixel Data Output (EG)
112	ER[5]	Pixel Data Output (ER)
113	ER[4]	Pixel Data Output (ER)
114	ER[3]	Pixel Data Output (ER)
115	ER[2]	Pixel Data Output (ER)
116	ER[1]	Pixel Data Output (ER)
117	ER[0]	Pixel Data Output (ER)
118	VSS	GND

Pin No.	Signal Name	Function
119	VSS	GND
120	VSS	GND
121	VSS	GND
122	LPF	Panel Clock PLL Filter
123	RSPI	Reference Terminal
124	NU	Not Used
125	CLKL	Clock Signal Output
126	OB[5]	Pixel Data Output (OB)
127	OB[4]	Pixel Data Output (OB)
128	OB[3]	Pixel Data Output (OB)
129	OB[2]	Pixel Data Output (OB)
130	OB[1]	Pixel Data Output (OB)
131	OB[0]	Pixel Data Output (OB)
132	OG[5]	Pixel Data Output (OG)
133	OG[4]	Pixel Data Output (OG)
134	VDD+3.3V	+3.3V VDD
135	VDD+3.3V	+3.3V VDD
136	VDD+3.3V	+3.3V VDD
137	OG[3]	Pixel Data Output (OG)
138	OG[2]	Pixel Data Output (OG)
139	OG[1]	Pixel Data Output (OG)
140	OG[0]	Pixel Data Output (OG)
141	OR[5]	Pixel Data Output (OR)
142	OR[4]	Pixel Data Output (OG)
143	OR[3]	Pixel Data Output (OG)
144	OR[2]	Pixel Data Output (OG)
145	VDD+1.2V	+1.2V VDD
146	VDD+1.2V	+1.2V VDD
147	OR[1]	Pixel Data Output (OG)
148	OR[0]	Pixel Data Output (OG)
149	STH	Start Pulse Signal
150	POL	Polarity Reverse Signal
151	LP	Latch Pulse Signal
152	DTV-ON-H	DTV On Signal at High
153	DTV-S-RESET	DTV Reset
154	NU	Not Used
155	DTV-S-SCLK	DTV Serial Clock
156	Clear	Panel Control Signal
157	BACKLIGHT-SW	Inverter Control Signal Output
158	BOOT-SEL	Boot Select
159	VSS	GND
160	VSS	GND

EXPLODED VIEWS

Cabinet

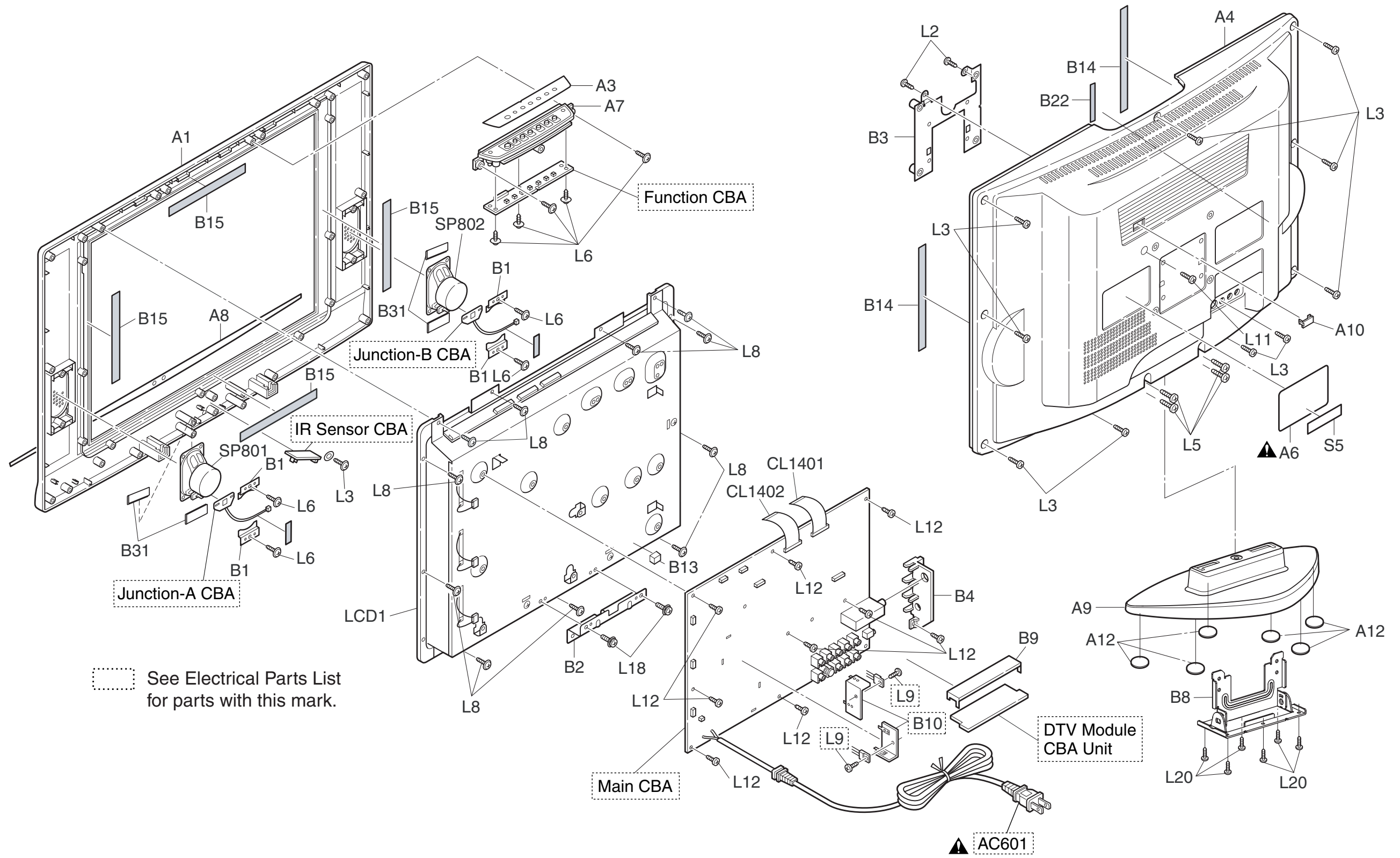

Packing

Some Ref. Numbers are not in sequence.

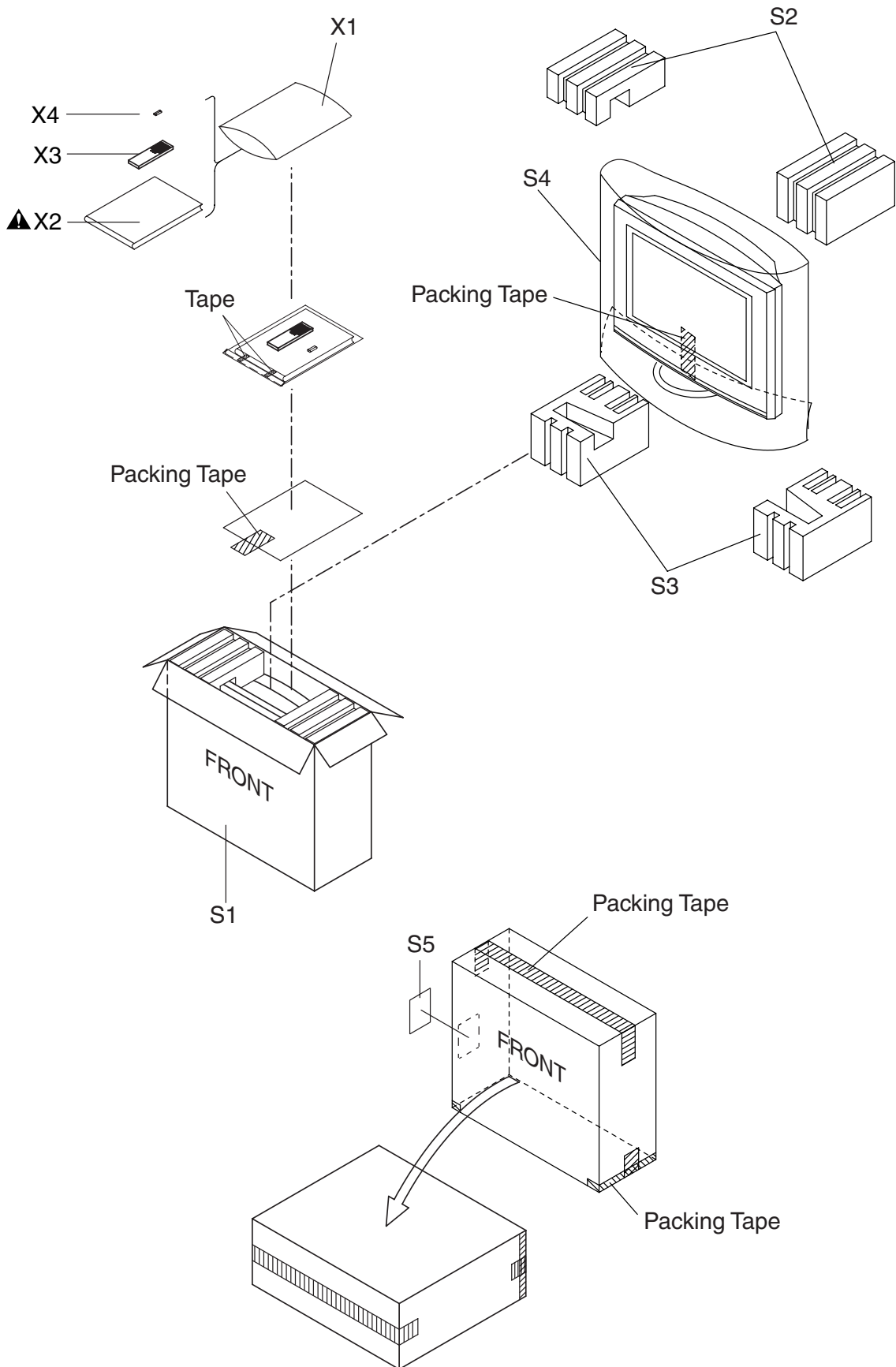

MECHANICAL PARTS LIST

PRODUCT SAFETY NOTE: Products marked with a  have special characteristics important to safety. Before replacing any of these components, read carefully the product safety notice in this service manual. Don't degrade the safety of the product through improper servicing.

NOTE: Parts that are not assigned part numbers (-----) are not available.

Ref. No.	Description	Part No.
A1	FRONT CABINET A7140UH	1EM121844
A3	CONTROL PLATE A7120UH	1EM322477
A4	REAR CABINET A7140UH	1EM121848
A6 	RATING LABEL A7140UH	-----
A7	FUNCTION KNOB L2530JA	1EM322170
A8	FRONT PLATE L3223UD	1EM221391
A9	STAND COVER A7140UH	1EM021662
A10	CONNECTER CAP A7140UH	1EM424251
A12	STAND RUBBER FOOT L4300UA	1EM422534
B1	SPEAKER HOLDER A7120UH	1EM423986
B2	TILT STAND HOLDER A7140UH	1EM322402
B3	STAND HOLDER L2500UA	1EM321428
B4	JACK HOLDER A7140UH	1EM322538
B8	ARM ASSEMBLY A7140UH	1EM221550
B9	MODULE PCB HOLDER P7150UZ	1EM322373
B13	RUBBER CUSHION L0170UA	1EM420551
B14	CLOTH(10X180XT0.5) L0336JG	0EM408827
B15	CLOTH 10X150XT1.0	1EM421092
B22	CLOTH(10X90XT1.0) A7120UH	1EM424258
B31	CLOTH(15X40XT0.5) A7140UH	1EM424366
CL1401	WIRE ASSEMBLY 35PIN FFC 35PIN/85MM	WX1A7140-006
CL1402	WIRE ASSEMBLY 33PIN FFC 33PIN/85MM	WX1A7140-005
L2	SCREW P-TIGHT M3X8 BIND HEAD+	GBJP3080
L3	SCREW P-TIGHT 3X10 BIND HEAD+	GBHP3100
L5	SCREW P-TIGHT M4X18 BIND HEAD+	GBHP4180
L6	SCREW P-TIGHT M3*10 WASHERHEAD+	GCJP3100
L8	SCREW P-TIGHT 3X14 WASHER HEAD+	GCJP3140
L11	SCREW S-TIGHT M3X8 BIND HEAD+	GBHS3080
L12	SCREW S-TIGHT M3X8 BIND HEAD+	GBJS3080
L18	DOUBLE SEMS SCREW M4X12 + BLAK	FPH34120
L20	SCREW B-TIGHT M4X8 BIND HEAD+ BLK	GBHB4080
LCD1	LCD MODULE LC5 20INCH	UF200XA
SP801	SPEAKER S0407F10	DSD0807XQ002
SP802	SPEAKER S0407F10	DSD0807XQ002
PACKING		
S1	CARTON A7140UH	1EM424243
S2	STYROFOAM TOP A7140UH	1EM021668
S3	STYROFOAM BOTTOM A7140UH	1EM021673
S4	SET BAG L0301UB	1EM320014A
S5	SERIAL NO. LABEL L9750UA	-----
ACCESSORIES		
X1	BAG POLYETHYLENE 235X365XT0.03	0EM408420A
X2 	OWNERS MANUAL A7140UH	1EMN22073
X3	REMOTE CONTROL NF600UD 170ECNLC501/ NF600UD	NF600UD
X4	DRY BATTERY R6UW/2S	XB0M311MS001

ELECTRICAL PARTS LIST

PRODUCT SAFETY NOTE: Products marked with a  have special characteristics important to safety. Before replacing any of these components, read carefully the product safety notice in this service manual. Don't degrade the safety of the product through improper servicing.

NOTES:

- Parts that are not assigned part numbers (-----) are not available.
- Tolerance of Capacitors and Resistors are noted with the following symbols.

C.....±0.25% D.....±0.5% F.....±1%
 G.....±2% J.....±5% K.....±10%
 M.....±20% N.....±30% Z.....+80/-20%

DTV MODULE CBA UNIT

Ref. No.	Description	Part No.
	DTV MODULE CBA UNIT	1ESA13964

MAIN CBA

Ref. No.	Description	Part No.
	MAIN CBA Consists of the following:	1ESA13798
CAPACITORS		
C22	ELECTROLYTIC CAP. 100µF/10V M	CE1AMASDL101
C23	CHIP CERAMIC CAP.(1608) CH J 1000pF/50V	CHD1JJ3CH102
C24	CHIP CERAMIC CAP.(1608) CH J 1000pF/50V	CHD1JJ3CH102
C25	CHIP CERAMIC CAP.(1608) B K 0.01µF/50V	CHD1JK30B103
C27	FILM CAP.(P) 0.018µF/50V J	CA1J183MS029
C28	CHIP CERAMIC CAP.(1608) B K 0.047µF/50V	CHD1JK30B473
C29	CHIP CERAMIC CAP. CH D 3pF/50V	CHD1JD3CH3R0
C31	PCB JUMPER D0.6-P5.0	JW5.0T
C32	ELECTROLYTIC CAP. 100µF/10V M	CE1AMASDL101
C34	CHIP CERAMIC CAP.(1608) CH J 47pF/50V	CHD1JJ3CH470
C35	ELECTROLYTIC CAP. 1µF/50V M	CE1JMASDL1R0
C36	CHIP CERAMIC CAP.(1608) CH J 47pF/50V	CHD1JJ3CH470
C37	CHIP CERAMIC CAP. CH J 680pF/50V	CHD1JJ3CH681
C39	ELECTROLYTIC CAP. 0.47µF/50V M	CE1JMASDLR47
C42	CHIP CERAMIC CAP.(1608) B K 0.01µF/50V	CHD1JK30B103
C46	PCB JUMPER D0.6-P5.0	JW5.0T
C47	CHIP CERAMIC CAP. CH D 5pF/50V	CHD1JD3CH5R0
C48	CERAMIC CAP.(AX) CH K 2.7pF/50V	CCA1JKTCH2R7
C60	CHIP CERAMIC CAP.(1608) CH J 33pF/50V	CHD1JJ3CH330
C62	ELECTROLYTIC CAP. 100µF/10V M	CE1AMASDL101
C63	ELECTROLYTIC CAP. 47µF/50V M	CE1JMASDL470
C64	CHIP CERAMIC CAP.(1608) B K 1000pF/50V	CHD1JK30B102
C67	CHIP CERAMIC CAP.(1608) F Z 0.1µF/25V	CHD1EZ30F104
C68	CHIP CERAMIC CAP.(1608) CH J 33pF/50V	CHD1JJ3CH330
C69	ELECTROLYTIC CAP. 1000µF/6.3V M	CE0KMASDL102
C71	CHIP CERAMIC CAP.(1608) CH J 47pF/50V	CHD1JJ3CH470
C72	CHIP CERAMIC CAP.(1608) CH J 47pF/50V	CHD1JJ3CH470
C74	CHIP CERAMIC CAP. F Z 1µF/10V	CHD1AZ30F105
C75	CHIP CERAMIC CAP. F Z 1µF/10V	CHD1AZ30F105
C77	CHIP CERAMIC CAP.(1608) F Z 0.1µF/25V	CHD1EZ30F104
C79	CHIP CERAMIC CAP.(1608) CH J 33pF/50V	CHD1JJ3CH330

Ref. No.	Description	Part No.
C83	CHIP RES.(1608) 1/10W 0 Ω	RRXAZR5Z0000
C85	CHIP CERAMIC CAP. CH J 330pF/50V	CHD1JJ3CH331
C86	CHIP CERAMIC CAP. CH J 330pF/50V	CHD1JJ3CH331
C87	CHIP CERAMIC CAP.(1608) B K 1000pF/50V	CHD1JK30B102
C89	CHIP CERAMIC CAP. CH J 220pF/50V	CHD1JJ3CH221
C90	ELECTROLYTIC CAP. 10µF/50V M	CE1JMASDL100
C91	CHIP CERAMIC CAP.(1608) B K 1000pF/50V	CHD1JK30B102
C401	ELECTROLYTIC CAP. 47µF/50V M	CE1JMASDL470
C402	CHIP CERAMIC CAP.(1608) B K 5600pF/50V	CHD1JK30B562
C403	ELECTROLYTIC CAP. 10µF/50V M	CE1JMASDL100
C405	ELECTROLYTIC CAP. 0.22µF/50V M	CE1JMASDLR22
C421	CAP CHIP 5pF 3KV C XC	CA3F5R05M016
C422	CHIP CERAMIC CAP.(1608) B K 0.01µF/50V	CHD1JK30B103
C423	CAP CHIP 5pF 3KV C XC	CA3F5R05M016
C425	CHIP CERAMIC CAP.(1608) B K 0.01µF/50V	CHD1JK30B103
C426	ELECTROLYTIC CAP. 10µF/50V M	CE1JMASDL100
C427	CHIP CERAMIC CAP.(1608) B K 0.01µF/50V	CHD1JK30B103
C428	ELECTROLYTIC CAP. 10µF/50V M	CE1JMASDL100
C429	CHIP CERAMIC CAP.(1608) B K 0.01µF/50V	CHD1JK30B103
C430	CAP METALIZED FILM 0.068µF/250V/J	CT2E683MS041
C431	ELECTROLYTIC CAP. 10µF/50V M	CE1JMASDL100
C432	CHIP CERAMIC CAP.(1608) B K 0.01µF/50V	CHD1JK30B103
C441	CAP CHIP 5pF 3KV C XC	CA3F5R05M016
C442	CHIP CERAMIC CAP.(1608) B K 0.01µF/50V	CHD1JK30B103
C443	CAP CHIP 5pF 3KV C XC	CA3F5R05M016
C445	CHIP CERAMIC CAP.(1608) B K 0.01µF/50V	CHD1JK30B103
C446	ELECTROLYTIC CAP. 10µF/50V M	CE1JMASDL100
C447	CHIP CERAMIC CAP.(1608) B K 0.01µF/50V	CHD1JK30B103
C448	ELECTROLYTIC CAP. 10µF/50V M	CE1JMASDL100
C449	CHIP CERAMIC CAP.(1608) B K 0.01µF/50V	CHD1JK30B103
C450	CAP METALIZED FILM 0.068µF/250V/J	CT2E683MS041
C451	ELECTROLYTIC CAP. 10µF/50V M	CE1JMASDL100
C461	CAP CHIP 5pF 3KV C XC	CA3F5R05M016
C462	CHIP CERAMIC CAP.(1608) B K 0.01µF/50V	CHD1JK30B103
C463	CAP CHIP 5pF 3KV C XC	CA3F5R05M016
C465	CHIP CERAMIC CAP.(1608) B K 0.01µF/50V	CHD1JK30B103
C466	ELECTROLYTIC CAP. 10µF/50V M	CE1JMASDL100
C467	CHIP CERAMIC CAP.(1608) B K 0.01µF/50V	CHD1JK30B103
C468	ELECTROLYTIC CAP. 10µF/50V M	CE1JMASDL100
C469	CHIP CERAMIC CAP.(1608) B K 0.01µF/50V	CHD1JK30B103
C470	CAP METALIZED FILM 0.068µF/250V/J	CT2E683MS041
C471	ELECTROLYTIC CAP. 10µF/50V M	CE1JMASDL100
C472	ELECTROLYTIC CAP. 10µF/50V M	CE1JMASDL100
C601 	METALIZED FILM CAP. 0.22µF/250V	CT2E224MS037
C608	CERAMIC CAP. 1000pF/2KV	CA3D102PAN04
C612	FILM CAP.(P) 0.027µF/50V J	CA1J273MS029
C613	FILM CAP.(P) 0.068µF/50V J	CMA1JJS00683
C614	FILM CAP.(P) 0.001µF/50V J	CA1J102MS029
C615	CAP ELE LS 270µF/200V/M/85	CA2D271V8006
C641 	SAFETY CAP. 4700pF/250V KX	CA2E472MR050
C659	CERAMIC CAP.(AX) B K 0.0015µF/50V	CA1J152TU011
C707	CHIP CERAMIC CAP.(1608) F Z 0.1µF/25V	CHD1EZ30F104
C708	CHIP CERAMIC CAP.(1608) CH J 100pF/50V	CHD1JJ3CH101
C713	CHIP CERAMIC CAP. B K 1500pF/50V	CHD1JK30B152
C714	CHIP CERAMIC CAP. F Z 1µF/10V	CHD1AZ30F105
C715	CHIP CERAMIC CAP. B K 1500pF/50V	CHD1JK30B152
C716	CHIP CERAMIC CAP. F Z 1µF/10V	CHD1AZ30F105
C740	CHIP CERAMIC CAP.(1608) CH J 100pF/50V	CHD1JJ3CH101
C751	CHIP CERAMIC CAP. F Z 1µF/10V	CHD1AZ30F105
C752	CHIP CERAMIC CAP. F Z 1µF/10V	CHD1AZ30F105

Ref. No.	Description	Part No.
C753	CHIP CERAMIC CAP. B K 1500pF/50V	CHD1JK30B152
C754	CHIP CERAMIC CAP. B K 1500pF/50V	CHD1JK30B152
C786	CHIP CERAMIC CAP.(1608) F Z 0.1μF/25V	CHD1EZ30F104
C801	ELECTROLYTIC CAP. 220μF/16V M	CE1CMASDL221
C802	ELECTROLYTIC CAP. 220μF/16V M	CE1CMASDL221
C805	ELECTROLYTIC CAP. 10μF/50V M	CE1JMASDL100
C806	CHIP CERAMIC CAP. F Z 1μF/10V	CHD1AZ30F105
C807	CHIP CERAMIC CAP. F Z 1μF/10V	CHD1AZ30F105
C809	ELECTROLYTIC CAP. 10μF/50V M	CE1JMASDL100
C810	ELECTROLYTIC CAP. 2.2μF/50V M	CE1JMASDL2R2
C811	ELECTROLYTIC CAP. 47μF/16V M	CE1CMASDL470
C812	CHIP CERAMIC CAP. F Z 1μF/10V	CHD1AZ30F105
C813	CHIP CERAMIC CAP. F Z 1μF/10V	CHD1AZ30F105
C818	ELECTROLYTIC CAP. 470μF/16V M	CE1CMASDL471
C819	CHIP CERAMIC CAP. CH J 680pF/50V	CHD1JJ3CH681
C820	CHIP CERAMIC CAP. CH J 680pF/50V	CHD1JJ3CH681
C821	CHIP CERAMIC CAP.(1608) F Z 0.1μF/25V	CHD1EZ30F104
C822	ELECTROLYTIC CAP. 10μF/50V M	CE1JMASDL100
C823	CHIP CERAMIC CAP.(1608) F Z 0.1μF/25V	CHD1EZ30F104
C824	CHIP CERAMIC CAP. CH J 180pF/50V	CHD1JJ3CH181
C825	CHIP CERAMIC CAP.(1608) F Z 0.1μF/25V	CHD1EZ30F104
C826	CHIP CERAMIC CAP.(1608) F Z 0.1μF/25V	CHD1EZ30F104
C827	CERAMIC CAP.(AX) F Z 0.1μF/50V	CCA1JZTFZ104
C853	ELECTROLYTIC CAP. 2.2μF/50V M	CE1JMASDL2R2
C854	CHIP CERAMIC CAP.(1608) B K 0.1μF/50V	CHD1JK30B104
C855	CHIP CERAMIC CAP.(1608) B K 0.1μF/50V	CHD1JK30B104
C856	CHIP CERAMIC CAP.(1608) B K 0.33μF/10V	CHD1AK30B334
C857	ELECTROLYTIC CAP. 2.2μF/50V M	CE1JMASDL2R2
C858	ELECTROLYTIC CAP. 2.2μF/50V M	CE1JMASDL2R2
C859	ELECTROLYTIC CAP. 4.7μF/50V M	CE1JMASDL4R7
C860	ELECTROLYTIC CAP. 10μF/50V M	CE1JMASDL100
C863	ELECTROLYTIC CAP. 2.2μF/50V M	CE1JMASDL2R2
C864	CHIP CERAMIC CAP.(1608) B K 0.022μF/50V	CHD1JK30B223
C865	CHIP CERAMIC CAP.(1608) B K 0.1μF/50V	CHD1JK30B104
C866	CHIP CERAMIC CAP. F Z 2.2μF/10V	CHD1AZ30F225
C867	CHIP CERAMIC CAP. F Z 2.2μF/10V	CHD1AZ30F225
C868	CHIP CERAMIC CAP.(1608) B K 1μF/10V	CHD1AK30B105
C869	CHIP CERAMIC CAP.(1608) B K 0.022μF/50V	CHD1JK30B223
C901	ELECTROLYTIC CAP. 2200μF/25V M	CE1EMZPDL222
C902	ELECTROLYTIC CAP. 470μF/25V M	CE1EMASDL471
C903	ELECTROLYTIC CAP. 1000μF/16V M	CE1EMZPDL102
C904	ELECTROLYTIC CAP. 0.47μF/50V M H7	CE1JMAVSLR47
C905	ELECTROLYTIC CAP. 1000μF/16V M	CE1EMZPDL102
C907	ELECTROLYTIC CAP. 100μF/50V M	CE1JMASDL101
C908	ELECTROLYTIC CAP. 1000μF/10V M	CE1AMASDL102
C909	ELECTROLYTIC CAP. 47μF/16V M	CE1CMASDL470
C910	ELECTROLYTIC CAP. 47μF/16V M	CE1CMASDL470
C911	ELECTROLYTIC CAP. 10μF/50V M	CE1JMASDL100
C912	ELECTROLYTIC CAP. 1μF/50V M	CE1JMASDL1R0
C913	FILM CAP.(P) 0.0027μF/50V J	CMA1JJS00272
C914	ELECTROLYTIC CAP. 100μF/10V M	CE1AMASDL101
C915	CHIP CERAMIC CAP.(1608) B K 0.1μF/50V	CHD1JK30B104
C916	ELECTROLYTIC CAP. 10μF/50V M	CE1JMASDL100
C920	ELECTROLYTIC CAP. 220μF/16V M	CE1CMASDL221
C926	CHIP CERAMIC CAP.(1608) CH J 47pF/50V	CHD1JJ3CH470
C1001	CHIP CERAMIC CAP.(1608) B K 0.01μF/50V	CHD1JK30B103
C1003	ELECTROLYTIC CAP. 220μF/16V M	CE1CMASDL221
C1004	CHIP CERAMIC CAP.(1608) B K 0.01μF/50V	CHD1JK30B103
C1005	ELECTROLYTIC CAP. 22μF/50V M	CE1JMASDL220
C1006	CHIP CERAMIC CAP.(1608) B K 0.01μF/50V	CHD1JK30B103
C1007	CHIP CERAMIC CAP.(1608) B K 0.01μF/50V	CHD1JK30B103
C1008	ELECTROLYTIC CAP. 10μF/16V M	CE1CMASDL100
C1204	CHIP CERAMIC CAP.(1608) F Z 0.1μF/25V	CHD1EZ30F104

Ref. No.	Description	Part No.
C1205	CHIP CERAMIC CAP.(1608) F Z 0.1μF/25V	CHD1EZ30F104
C1206	ELECTROLYTIC CAP. 100μF/16V M	CE1CMASDL101
C1207	CHIP CERAMIC CAP.(1608) F Z 0.1μF/25V	CHD1EZ30F104
C1208	ELECTROLYTIC CAP. 100μF/16V M	CE1CMASDL101
C1209	CHIP CERAMIC CAP.(1608) CH J 100pF/50V	CHD1JJ3CH101
C1210	CHIP CERAMIC CAP.(1608) B K 0.01μF/50V	CHD1JK30B103
C1211	CHIP CERAMIC CAP.(1608) F Z 0.1μF/25V	CHD1EZ30F104
C1213	CHIP CERAMIC CAP.(1608) F Z 0.1μF/25V	CHD1EZ30F104
C1214	ELECTROLYTIC CAP. 47μF/16V M	CE1CMASDL470
C1216	CHIP CERAMIC CAP.(1608) F Z 0.1μF/25V	CHD1EZ30F104
C1217	ELECTROLYTIC CAP. 47μF/16V M	CE1CMASDL470
C1218	CHIP CERAMIC CAP.(1608) F Z 0.1μF/25V	CHD1EZ30F104
C1219	ELECTROLYTIC CAP. 47μF/16V M	CE1CMASDL470
C1301	CHIP CERAMIC CAP.(1608) B K 0.01μF/50V	CHD1JK30B103
C1302	CHIP CERAMIC CAP.(1608) B K 0.1μF/50V	CHD1JK30B104
C1304	CHIP CERAMIC CAP. CH J 330pF/50V	CHD1JJ3CH331
C1311	ELECTROLYTIC CAP. 47μF/16V M	CE1CMASDL470
C1312	CHIP CERAMIC CAP.(1608) F Z 0.1μF/25V	CHD1EZ30F104
C1313	CHIP CERAMIC CAP.(1608) F Z 0.1μF/25V	CHD1EZ30F104
C1314	CHIP CERAMIC CAP.(1608) F Z 0.1μF/25V	CHD1EZ30F104
C1315	ELECTROLYTIC CAP. 47μF/16V M	CE1CMASDL470
C1316	CHIP CERAMIC CAP.(1608) F Z 0.1μF/25V	CHD1EZ30F104
C1317	ELECTROLYTIC CAP. 47μF/16V M	CE1CMASDL470
C1319	CHIP CERAMIC CAP.(1608) CH J 47pF/50V	CHD1JJ3CH470
C1320	CHIP CERAMIC CAP.(1608) CH J 47pF/50V	CHD1JJ3CH470
C1321	CHIP CERAMIC CAP.(1608) CH J 33pF/50V	CHD1JJ3CH330
C1322	CHIP CERAMIC CAP.(1608) CH J 33pF/50V	CHD1JJ3CH330
C1323	CHIP CERAMIC CAP.(1608) B K 0.01μF/50V	CHD1JK30B103
C1324	ELECTROLYTIC CAP. 100μF/16V M	CE1CMASDL101
C1331	CHIP CERAMIC CAP.(1608) F Z 0.1μF/25V	CHD1EZ30F104
C1332	ELECTROLYTIC CAP. 47μF/16V M	CE1CMASDL470
C1334	CHIP CERAMIC CAP.(1608) B K 0.1μF/50V	CHD1JK30B104
C1335	CHIP CERAMIC CAP.(1608) B K 0.1μF/50V	CHD1JK30B104
C1336	CHIP CERAMIC CAP.(1608) F Z 0.1μF/25V	CHD1EZ30F104
C1337	CHIP CERAMIC CAP.(1608) B K 0.1μF/50V	CHD1JK30B104
C1338	CHIP CERAMIC CAP.(1608) F Z 0.1μF/25V	CHD1EZ30F104
C1339	CHIP CERAMIC CAP.(1608) F Z 0.1μF/25V	CHD1EZ30F104
C1340	CHIP CERAMIC CAP.(1608) F Z 0.1μF/25V	CHD1EZ30F104
C1341	ELECTROLYTIC CAP. 47μF/16V M	CE1CMASDL470
C1342	CHIP CERAMIC CAP.(1608) B K 0.1μF/50V	CHD1JK30B104
C1343	CHIP CERAMIC CAP.(1608) B K 0.1μF/50V	CHD1JK30B104
C1344	CHIP CERAMIC CAP.(1608) F Z 0.1μF/25V	CHD1EZ30F104
C1345	CHIP CERAMIC CAP.(1608) B K 0.1μF/50V	CHD1JK30B104
C1346	CHIP CERAMIC CAP.(1608) F Z 0.1μF/25V	CHD1EZ30F104
C1347	CHIP CERAMIC CAP.(1608) F Z 0.1μF/25V	CHD1EZ30F104
C1348	CHIP CERAMIC CAP.(1608) F Z 0.1μF/25V	CHD1EZ30F104
C1349	ELECTROLYTIC CAP. 47μF/16V M	CE1CMASDL470
C1350	CHIP CERAMIC CAP.(1608) B K 0.1μF/50V	CHD1JK30B104
C1351	CHIP CERAMIC CAP.(1608) F Z 0.1μF/25V	CHD1EZ30F104
C1352	CHIP CERAMIC CAP.(1608) B K 0.1μF/50V	CHD1JK30B104
C1353	CHIP CERAMIC CAP.(1608) F Z 0.1μF/25V	CHD1EZ30F104
C1355	CHIP CERAMIC CAP.(1608) B K 0.1μF/50V	CHD1JK30B104
C1356	CHIP CERAMIC CAP.(1608) F Z 0.1μF/25V	CHD1EZ30F104
C1359	CHIP CERAMIC CAP.(1608) F Z 0.1μF/25V	CHD1EZ30F104
C1360	CHIP CERAMIC CAP.(1608) F Z 0.1μF/25V	CHD1EZ30F104
C1361	ELECTROLYTIC CAP. 47μF/16V M	CE1CMASDL470
C1362	CHIP CERAMIC CAP. F Z 1μF/10V	CHD1AZ30F105
C1366	CHIP CERAMIC CAP.(1608) F Z 0.1μF/25V	CHD1EZ30F104
C1367	CHIP CERAMIC CAP.(1608) F Z 0.1μF/25V	CHD1EZ30F104
C1368	CHIP CERAMIC CAP.(1608) F Z 0.1μF/25V	CHD1EZ30F104
C1369	CERAMIC CAP.(AX) B K 1000pF/50V	CCA1JKT0B102
C1374	CHIP CERAMIC CAP.(1608) F Z 0.1μF/25V	CHD1EZ30F104
C1375	CHIP CERAMIC CAP.(1608) F Z 0.1μF/25V	CHD1EZ30F104

Ref. No.	Description	Part No.
C1705	CHIP CERAMIC CAP. F Z 1 μ F/10V	CHD1AZ30F105
CONNECTORS		
CN401	BACK LIGHT CONNECTOR 1717369-1	JB17D02AP001
CN402	BACK LIGHT CONNECTOR 1717369-1	JB17D02AP001
CN403	BACK LIGHT CONNECTOR 1717369-1	JB17D02AP001
CN1201	FMN CONNECTOR SIDE 35P 35FMN-STRK-A(LF)(SN)	JCFNG35JG022
CN1202	FMN CONNECTOR SIDE 33P 33FMN-STRK-A(LF)(SN)	JCFNG33JG022
CN1303	PH CONNECTOR TOP 4P B4B-PH-K-S (LF)(SN)	J3PHC04JG029
DIODES		
D31	SWITCHING DIODE 1SS133(T-77)	QDTZ001SS133
D62	SWITCHING DIODE 1SS133(T-77)	QDTZ001SS133
D63	SWITCHING DIODE 1SS133(T-77)	QDTZ001SS133
D68	SWITCHING DIODE 1SS133(T-77)	QDTZ001SS133
D401	SWITCHING DIODE 1SS133(T-77)	QDTZ001SS133
D402	SWITCHING DIODE 1SS133(T-77)	QDTZ001SS133
D403	ZENER DIODE MTZJT-775.5B	QDTB0MTZJ7R5
D404	SWITCHING DIODE 1SS133(T-77)	QDTZ001SS133
D406	SWITCHING DIODE 1SS133(T-77)	QDTZ001SS133
D407	SWITCHING DIODE 1SS133(T-77)	QDTZ001SS133
D408	ZENER DIODE MTZJT-776.2B	QDTB0MTZJ6R2
D409	ZENER DIODE MTZJT-7710B	QDTB00MTZJ10
D410	ZENER DIODE MTZJT-775.6B	QDTB0MTZJ5R6
D411	ZENER DIODE MTZJT-775.6B	QDTB0MTZJ5R6
D421	SWITCHING DIODE 1SS133(T-77)	QDTZ001SS133
D422	SWITCHING DIODE 1SS133(T-77)	QDTZ001SS133
D423	SWITCHING DIODE 1SS133(T-77)	QDTZ001SS133
D424	SWITCHING DIODE 1SS133(T-77)	QDTZ001SS133
D425	SWITCHING DIODE 1SS133(T-77)	QDTZ001SS133
D426	SWITCHING DIODE 1SS133(T-77)	QDTZ001SS133
D427	SWITCHING DIODE 1SS133(T-77)	QDTZ001SS133
D428	SWITCHING DIODE 1SS133(T-77)	QDTZ001SS133
D429	SWITCHING DIODE 1SS133(T-77)	QDTZ001SS133
D430	SWITCHING DIODE 1SS133(T-77)	QDTZ001SS133
D431	SWITCHING DIODE 1SS133(T-77)	QDTZ001SS133
D432	SWITCHING DIODE 1SS133(T-77)	QDTZ001SS133
D433	SWITCHING DIODE 1SS133(T-77)	QDTZ001SS133
D434	SWITCHING DIODE 1SS133(T-77)	QDTZ001SS133
D441	SWITCHING DIODE 1SS133(T-77)	QDTZ001SS133
D442	SWITCHING DIODE 1SS133(T-77)	QDTZ001SS133
D443	SWITCHING DIODE 1SS133(T-77)	QDTZ001SS133
D444	SWITCHING DIODE 1SS133(T-77)	QDTZ001SS133
D445	SWITCHING DIODE 1SS133(T-77)	QDTZ001SS133
D446	SWITCHING DIODE 1SS133(T-77)	QDTZ001SS133
D447	SWITCHING DIODE 1SS133(T-77)	QDTZ001SS133
D448	SWITCHING DIODE 1SS133(T-77)	QDTZ001SS133
D449	SWITCHING DIODE 1SS133(T-77)	QDTZ001SS133
D450	SWITCHING DIODE 1SS133(T-77)	QDTZ001SS133
D451	SWITCHING DIODE 1SS133(T-77)	QDTZ001SS133
D452	SWITCHING DIODE 1SS133(T-77)	QDTZ001SS133
D453	SWITCHING DIODE 1SS133(T-77)	QDTZ001SS133
D454	SWITCHING DIODE 1SS133(T-77)	QDTZ001SS133
D461	SWITCHING DIODE 1SS133(T-77)	QDTZ001SS133
D462	SWITCHING DIODE 1SS133(T-77)	QDTZ001SS133
D463	SWITCHING DIODE 1SS133(T-77)	QDTZ001SS133
D464	SWITCHING DIODE 1SS133(T-77)	QDTZ001SS133
D465	SWITCHING DIODE 1SS133(T-77)	QDTZ001SS133
D466	SWITCHING DIODE 1SS133(T-77)	QDTZ001SS133
D467	SWITCHING DIODE 1SS133(T-77)	QDTZ001SS133
D468	SWITCHING DIODE 1SS133(T-77)	QDTZ001SS133
D469	SWITCHING DIODE 1SS133(T-77)	QDTZ001SS133

Ref. No.	Description	Part No.
D470	SWITCHING DIODE 1SS133(T-77)	QDTZ001SS133
D471	SWITCHING DIODE 1SS133(T-77)	QDTZ001SS133
D472	SWITCHING DIODE 1SS133(T-77)	QDTZ001SS133
D473	SWITCHING DIODE 1SS133(T-77)	QDTZ001SS133
D474	SWITCHING DIODE 1SS133(T-77)	QDTZ001SS133
D605▲	DIODE 1N5397-B	NDLZ001N5397
D606▲	DIODE 1N5397-B	NDLZ001N5397
D607▲	DIODE 1N5397-B	NDLZ001N5397
D608▲	DIODE 1N5397-B	NDLZ001N5397
D609	ZENER DIODE MTZJT-775.6B	QDTB0MTZJ5R6
D611▲	ZENER DIODE MTZJT-7722B	QDTB00MTZJ22
D612	PCB JUMPER D0.6-P5.0	JW5.0T
D613	SWITCHING DIODE 1SS133(T-77)	QDTZ001SS133
D614	SWITCHING DIODE 1SS133(T-77)	QDTZ001SS133
D624▲	ZENER DIODE MTZJT-7739B	QDTB00MTZJ39
D801	SWITCHING DIODE 1SS133(T-77)	QDTZ001SS133
D802	SWITCHING DIODE 1SS133(T-77)	QDTZ001SS133
D803	ZENER DIODE MTZJT-776.2B	QDTB0MTZJ6R2
D901	SCHOTTKY BARRIER DIODE ERC84-009	QDLZERC84009
D902	RECTIFIER DIODE FR202-B/P	NDQZ000FR202
D903	SCHOTTKY BARRIER DIODE 21DQ04	QDQZ0021DQ04
D905	ZENER DIODE MTZJT-777.5C	QDTC0MTZJ7R5
D906	SCHOTTKY BARRIEA DIODE 11EQS04	QD4Z001EQS04
D909	DIODE FR154	NDLZ000FR154
D910	DIODE 1ZC43(Q)	QDLZ001ZC43Q
D911	SCHOTTKY BARRIER DIODE SB240-B/P	NDQZ000SB240
D913	DIODE FR104-B	NDLZ000FR104
D914	SWITCHING DIODE 1SS133(T-77)	QDTZ001SS133
D915	SWITCHING DIODE 1SS133(T-77)	QDTZ001SS133
D916	IC SHUNT REGULATOR KIA431-AT/P	NSZBA0TJY036
D917	SWITCHING DIODE 1SS133(T-77)	QDTZ001SS133
D919	SWITCHING DIODE 1SS133(T-77)	QDTZ001SS133
D920	IC SHUNT REGULATOR KIA431-AT/P	NSZBA0TJY036
D921	ZENER DIODE MTZJT-775.6C	QDTC0MTZJ5R6
D922	ZENER DIODE MTZJT-775.6C	QDTC0MTZJ5R6
D923	IC SHUNT REGULATOR KIA431-AT/P	NSZBA0TJY036
D924	IC SHUNT REGULATOR KIA431-AT/P	NSZBA0TJY036
D925	SWITCHING DIODE 1SS133(T-77)	QDTZ001SS133
D926	ZENER DIODE MTZJT-7739B	QDTB00MTZJ39
D927	SWITCHING DIODE 1SS133(T-77)	QDTZ001SS133
D928	ZENER DIODE MTZJT-7733B	QDTB00MTZJ33
D931	DIODE FR154	NDLZ000FR154
D932	SCHOTTKY BARRIEA DIODE 11EQS04	QD4Z001EQS04
D933	ZENER DIODE MTZJT-775.6B	QDTB0MTZJ5R6
D934	SWITCHING DIODE 1SS133(T-77)	QDTZ001SS133
D940	ZENER DIODE MTZJT-7710B	QDTB00MTZJ10
D941	SWITCHING DIODE 1SS133(T-77)	QDTZ001SS133
D942	SWITCHING DIODE 1SS133(T-77)	QDTZ001SS133
D943	SWITCHING DIODE 1SS133(T-77)	QDTZ001SS133
D945	SWITCHING DIODE 1SS133(T-77)	QDTZ001SS133
D946	SWITCHING DIODE 1SS133(T-77)	QDTZ001SS133
D947	PCB JUMPER D0.6-P5.0	JW5.0T
D948	PCB JUMPER D0.6-P5.0	JW5.0T
D949	SWITCHING DIODE 1SS133(T-77)	QDTZ001SS133
D951	SWITCHING DIODE 1SS133(T-77)	QDTZ001SS133
D952	SWITCHING DIODE 1SS133(T-77)	QDTZ001SS133
D955	SWITCHING DIODE 1SS133(T-77)	QDTZ001SS133
D956	ZENER DIODE MTZJT-7712B	QDTB00MTZJ12
D957	SWITCHING DIODE 1SS133(T-77)	QDTZ001SS133
D960	SWITCHING DIODE 1SS133(T-77)	QDTZ001SS133
D961	SWITCHING DIODE 1SS133(T-77)	QDTZ001SS133
D962	SWITCHING DIODE 1SS133(T-77)	QDTZ001SS133
D963	SWITCHING DIODE 1SS133(T-77)	QDTZ001SS133

Ref. No.	Description	Part No.
D1001	SWITCHING DIODE 1SS133(T-77)	QDTZ001SS133
D1002	IC SHUNT REGULATOR KIA431-AT/P	NSZBA0TJY036
D1003	SWITCHING DIODE 1SS133(T-77)	QDTZ001SS133
D1004	ZENER DIODE MTZJT-7724B	QDTB00MTZJ24
D1005	ZENER DIODE MTZJT-776.2B	QDTB0MTZJ6R2
D1205	ZENER DIODE MTZJT-774.3B	QDTB0MTZJ4R3
ICS		
IC31	IC VIF/SIF M61116FP TF0G	QSZBA0SHT034
IC61	EEP-ROM 128K M24128-BWMN6TP	NSZBA0TSS268
IC601▲	PHOTOCOUPLER LTV-817C-F	NPEC0LTV817F
IC801	IC AUDIO SA7412	NSZBA0SQ0007
IC851	IC MTS RECORDER AN5832SA-E1V	QSZBA0TMS003
IC852	IC SWITCHING TC4052BF(ELNF)	QSZBA0TTS162
IC901	VOLTAGE REGULATOR LD1117SC-R	NSZBA0TSS229
IC904	VOLTAGE REGULATOR PQ070XF01SZH	QSZBA0SSH054
IC905	IC VOLTAGE REGULATOR 5V KIA7805AP/P	NSZBA0SJY041
IC1202	IC DVP-V6 R8A02030A91FP-RF0Z	QSZAA0RHT155
IC1205	IC BR24L64F-WE2	QSZBA0TRM071
COILS		
L21	PCB JUMPER D0.6-P5.0	JW5.0T
L22	INDUCTOR 150μH-J-26T	LLAXJATTU151
L31	PCB JUMPER D0.6-P5.0	JW5.0T
L32	INDUCTOR 18μH-J-26T	LLAXJATTU180
L61	PCB JUMPER D0.6-P5.0	JW5.0T
L63	PCB JUMPER D0.6-P5.0	JW5.0T
L66	INDUCTOR CHIP LK16081R0K-T 1.0μH	LLACKB3TU1R0
L401	COIL CHOKE ELC10D101EL	LLC101KMS003
L402	COIL CHOKE ELC10D101EL	LLC101KMS003
L403	COIL CHOKE ELC10D101EL	LLC101KMS003
L601▲	LINE FILTER 5.0MH 6Y075	LLBG00ZKT004
L701	PCB JUMPER D0.6-P5.0	JW5.0T
L781	PCB JUMPER D0.6-P5.0	JW5.0T
L851	PCB JUMPER D0.6-P5.0	JW5.0T
L1200	CHIP RES. 1/10W J 100 Ω	RRXAJR5Z0101
L1301	PCB JUMPER D0.6-P5.0	JW5.0T
L1338	INDUCTOR 1.0μH-J-26T	LLAXJATTU010
L1346	INDUCTOR 1.0μH-J-26T	LLAXJATTU010
L1351	INDUCTOR 1.0μH-J-26T	LLAXJATTU010
L1356	INDUCTOR 1.0μH-J-26T	LLAXJATTU010
TRANSISTORS		
Q401	NPN TRANSISTOR POWER 2SC4881F HFE MAX320	QQWZ2SC4881F
Q402	TRANSISTOR 2SA950-Y(T E2 F T)	QQSY02SA950F
Q403	TRANSISTOR 2SC2785(F)	QQSF02SC2785
Q404	TRANSISTOR 2SC2785(F)	QQSF02SC2785
Q405	TRANSISTOR 2SA1175(F)	QQSF02SA1175
Q406	TRANSISTOR 2SC2120-Y(T E2 F T)	QQSY2SC2120F
Q407	TRANSISTOR 2SC2785(F)	QQSF02SC2785
Q421▲	FET MOS SMD TPC8214-H	QF2ZTPC8214H
Q422	TRANSISTOR 2SC2785(F)	QQSF02SC2785
Q423	TRANSISTOR 2SC2785(F)	QQSF02SC2785
Q424	TRANSISTOR 2SC2785(F)	QQSF02SC2785
Q425	TRANSISTOR 2SC2785(F)	QQSF02SC2785
Q441▲	FET MOS SMD TPC8214-H	QF2ZTPC8214H
Q442	TRANSISTOR 2SC2785(F)	QQSF02SC2785
Q443	TRANSISTOR 2SC2785(F)	QQSF02SC2785
Q444	TRANSISTOR 2SC2785(F)	QQSF02SC2785
Q461▲	FET MOS SMD TPC8214-H	QF2ZTPC8214H
Q462	TRANSISTOR 2SC2785(F)	QQSF02SC2785
Q463	TRANSISTOR 2SC2785(F)	QQSF02SC2785
Q464	TRANSISTOR 2SC2785(F)	QQSF02SC2785
Q601▲	FET MOS 2SK3563(Q)	QFWZ2SK3563Q
Q603▲	TRANSISTOR 2SC2120-Y(T E2 F T)	QQSY2SC2120F

Ref. No.	Description	Part No.
Q707	TRANSISTOR 2SC2785(F)	QQSF02SC2785
Q708	TRANSISTOR 2SC2785(F)	QQSF02SC2785
Q709	TRANSISTOR 2SC2785(F)	QQSF02SC2785
Q802	TRANSISTOR 2SC2785(F)	QQSF02SC2785
Q901	TRANSISTOR 2SC2120-Y(T E2 F T)	QQSY2SC2120F
Q902	TRANSISTOR 2SC2120-Y(T E2 F T)	QQSY2SC2120F
Q903	TRANSISTOR 2SC2120-Y(T E2 F T)	QQSY2SC2120F
Q905	TRANSISTOR 2SA950-Y(T E2 F T)	QQSY02SA950F
Q906	TRANSISTOR 2SC2785(F)	QQSF02SC2785
Q907	TRANSISTOR 2SC2120-Y(T E2 F T)	QQSY2SC2120F
Q908	TRANSISTOR 2SC2120-Y(T E2 F T)	QQSY2SC2120F
Q909	TRANSISTOR 2SC2120-Y(T E2 F T)	QQSY2SC2120F
Q910	TRANSISTOR 2SA1175(F)	QQSF02SA1175
Q913	TRANSISTOR 2SC2785(F)	QQSF02SC2785
Q916	TRANSISTOR 2SC2785(F)	QQSF02SC2785
Q917	TRANSISTOR 2SC2785(F)	QQSF02SC2785
Q918	TRANSISTOR 2SC2785(F)	QQSF02SC2785
Q919	TRANSISTOR 2SC2785(F)	QQSF02SC2785
Q923	TRANSISTOR 2SA950-Y(T E2 F T)	QQSY02SA950F
Q1001	TRANSISTOR 2SC2785(F)	QQSF02SC2785
Q1002	TRANSISTOR 2SA1175(F)	QQSF02SA1175
Q1003	TRANSISTOR 2SC2120-Y(T E2 F T)	QQSY2SC2120F
Q1004	TRANSISTOR 2SC2785(F)	QQSF02SC2785
Q1005	TRANSISTOR 2SA1175(F)	QQSF02SA1175
Q1006	TRANSISTOR 2SC2785(F)	QQSF02SC2785
Q1007	TRANSISTOR 2SC2785(F)	QQSF02SC2785
RESISTORS		
R17	CHIP RES.(1608) 1/10W 0 Ω	RRXAZR5Z0000
R18	CHIP RES.(1608) 1/10W 0 Ω	RRXAZR5Z0000
R21	CHIP RES. 1/10W J 270k Ω	RRXAJR5Z0274
R23	CHIP RES. 1/10W J 2.2k Ω	RRXAJR5Z0222
R24	CHIP RES. 1/10W J 820k Ω	RRXAJR5Z0824
R25	CHIP RES. 1/10W J 8.2k Ω	RRXAJR5Z0822
R26	CARBON RES. 1/4W J 100 Ω	RCX4JATZ0101
R34	CHIP RES.(1608) 1/10W 0 Ω	RRXAZR5Z0000
R38	CHIP RES. 1/10W J 100 Ω	RRXAJR5Z0101
R42	CHIP RES. 1/10W J 220 Ω	RRXAJR5Z0221
R46	CARBON RES. 1/4W J 1k Ω	RCX4JATZ0102
R48	CHIP RES.(1608) 1/10W 0 Ω	RRXAZR5Z0000
R49	CHIP RES. 1/10W J 1.8k Ω	RRXAJR5Z0182
R61	CHIP RES. 1/10W J 220 Ω	RRXAJR5Z0221
R62	CHIP RES. 1/10W J 220 Ω	RRXAJR5Z0221
R63	CHIP RES.(1608) 1/10W 0 Ω	RRXAZR5Z0000
R64	CHIP RES.(1608) 1/10W 0 Ω	RRXAZR5Z0000
R65	CHIP RES.(1608) 1/10W 0 Ω	RRXAZR5Z0000
R67	CHIP RES.(1608) 1/10W 0 Ω	RRXAZR5Z0000
R68	CHIP RES.(1608) 1/10W 0 Ω	RRXAZR5Z0000
R72	CHIP RES.(1608) 1/10W 0 Ω	RRXAZR5Z0000
R73	CHIP RES. 1/10W J 22k Ω	RRXAJR5Z0223
R74	CHIP RES. 1/10W J 22k Ω	RRXAJR5Z0223
R75	CHIP RES. 1/10W J 10k Ω	RRXAJR5Z0103
R401	CHIP RES. 1/10W J 1.5k Ω	RRXAJR5Z0152
R402	CARBON RES. 1/4W J 27k Ω	RCX4JATZ0273
R403	CARBON RES. 1/4W J 150 Ω	RCX4JATZ0151
R404	CARBON RES. 1/4W J 5.6k Ω	RCX4JATZ0562
R406	CHIP RES. 1/10W J 3.3k Ω	RRXAJR5Z0332
R407	CHIP RES. 1/10W J 10k Ω	RRXAJR5Z0103
R408	CARBON RES. 1/4W J 820 Ω	RCX4JATZ0821
R409	CARBON RES. 1/4W J 10k Ω	RCX4JATZ0103
R410	CARBON RES. 1/4W J 1.2k Ω	RCX4JATZ0122
R411	CHIP RES. 1/10W J 1 Ω	RRXAJR5Z01R0
R412	CHIP RES. 1/10W J 10k Ω	RRXAJR5Z0103

Ref. No.	Description	Part No.
R413	CHIP RES. 1/10W J 33k Ω	RRXAJR5Z0333
R414	CARBON RES. 1/4W J 680 Ω	RCX4JATZ0681
R415	CARBON RES. 1/4W J 150 Ω	RCX4JATZ0151
R416	CARBON RES. 1/4W J 150 Ω	RCX4JATZ0151
R417	CARBON RES. 1/4W J 150 Ω	RCX4JATZ0151
R418	CARBON RES. 1/4W J 1.2k Ω	RCX4JATZ0122
R419	CARBON RES. 1/4W J 150 Ω	RCX4JATZ0151
R420	CHIP RES. 1/10W J 10k Ω	RRXAJR5Z0103
R421	CHIP RES. 1/10W J 390 Ω	RRXAJR5Z0391
R422	CHIP RES. 1/10W J 390 Ω	RRXAJR5Z0391
R423	CHIP RES. 1/10W J 1k Ω	RRXAJR5Z0102
R424	CHIP RES. 1/10W J 10k Ω	RRXAJR5Z0103
R425	CHIP RES. 1/10W J 10k Ω	RRXAJR5Z0103
R426	CHIP RES. 1/10W J 1k Ω	RRXAJR5Z0102
R427	CHIP RES. 1/10W J 10k Ω	RRXAJR5Z0103
R428	CHIP RES. 1/10W J 22 Ω	RRXAJR5Z0220
R429	CHIP RES. 1/10W J 22 Ω	RRXAJR5Z0220
R430	CHIP RES. 1/10W J 4.7k Ω	RRXAJR5Z0472
R431	CHIP RES. 1/10W J 4.7k Ω	RRXAJR5Z0472
R432	CHIP RES. 1/10W J 10k Ω	RRXAJR5Z0103
R433	CHIP RES. 1/10W J 10k Ω	RRXAJR5Z0103
R434	CHIP RES. 1/10W J 15k Ω	RRXAJR5Z0153
R435	CHIP RES. 1/10W J 2.2k Ω	RRXAJR5Z0222
R436	CHIP RES. 1/10W J 10k Ω	RRXAJR5Z0103
R437	CHIP RES. 1/10W J 10k Ω	RRXAJR5Z0103
R438	CHIP RES. 1/10W J 3.3k Ω	RRXAJR5Z0332
R441	CHIP RES. 1/10W J 390 Ω	RRXAJR5Z0391
R442	CHIP RES. 1/10W J 390 Ω	RRXAJR5Z0391
R443	CHIP RES. 1/10W J 1k Ω	RRXAJR5Z0102
R444	CHIP RES. 1/10W J 10k Ω	RRXAJR5Z0103
R445	CHIP RES. 1/10W J 1k Ω	RRXAJR5Z0102
R446	CHIP RES. 1/10W J 10k Ω	RRXAJR5Z0103
R447	CHIP RES. 1/10W J 22 Ω	RRXAJR5Z0220
R448	CHIP RES. 1/10W J 22 Ω	RRXAJR5Z0220
R449	CHIP RES. 1/10W J 4.7k Ω	RRXAJR5Z0472
R450	CHIP RES. 1/10W J 4.7k Ω	RRXAJR5Z0472
R451	CHIP RES. 1/10W J 10k Ω	RRXAJR5Z0103
R452	CHIP RES. 1/10W J 10k Ω	RRXAJR5Z0103
R453	CHIP RES. 1/10W J 10k Ω	RRXAJR5Z0103
R456	CHIP RES. 1/10W J 10k Ω	RRXAJR5Z0103
R457	CHIP RES. 1/10W J 10k Ω	RRXAJR5Z0103
R461	CHIP RES. 1/10W J 390 Ω	RRXAJR5Z0391
R462	CHIP RES. 1/10W J 390 Ω	RRXAJR5Z0391
R463	CHIP RES. 1/10W J 1k Ω	RRXAJR5Z0102
R464	CHIP RES. 1/10W J 10k Ω	RRXAJR5Z0103
R465	CHIP RES. 1/10W J 1k Ω	RRXAJR5Z0102
R466	CHIP RES. 1/10W J 10k Ω	RRXAJR5Z0103
R467	CHIP RES. 1/10W J 22 Ω	RRXAJR5Z0220
R468	CHIP RES. 1/10W J 22 Ω	RRXAJR5Z0220
R469	CHIP RES. 1/10W J 4.7k Ω	RRXAJR5Z0472
R470	CHIP RES. 1/10W J 4.7k Ω	RRXAJR5Z0472
R471	CHIP RES. 1/10W J 10k Ω	RRXAJR5Z0103
R472	CHIP RES. 1/10W J 10k Ω	RRXAJR5Z0103
R473	CHIP RES. 1/10W J 10k Ω	RRXAJR5Z0103
R474	CHIP RES. 1/10W J 100 Ω	RRXAJR5Z0101
R476	CHIP RES. 1/10W J 10k Ω	RRXAJR5Z0103
R477	CHIP RES. 1/10W J 10k Ω	RRXAJR5Z0103
R601▲	CEMENT RES. 3W K 1.2 Ω	RW031R2PG007
R603	CARBON RES. 1/4W J 390k Ω	RCX4JATZ0394
R604	CARBON RES. 1/4W J 390k Ω	RCX4JATZ0394
R605	CARBON RES. 1/4W J 390k Ω	RCX4JATZ0394
R607	CARBON RES. 1/4W J 180 Ω	RCX4JATZ0181
R608	CARBON RES. 1/4W J 220 Ω	RCX4JATZ0221

Ref. No.	Description	Part No.
R609	CARBON RES. 1/4W J 390k Ω	RCX4JATZ0394
R610	CARBON RES. 1/4W J 150 Ω	RCX4JATZ0151
R613▲	METAL OXIDE FILM RES. 2W J 0.47 Ω	RN02R47ZU001
R621	CARBON RES. 1/4W J 1.2k Ω	RCX4JATZ0122
R623	CARBON RES. 1/4W J 2.2k Ω	RCX4JATZ0222
R707	CHIP RES. 1/10W J 100 Ω	RRXAJR5Z0101
R708	CHIP RES. 1/10W J 10k Ω	RRXAJR5Z0103
R709	CHIP RES. 1/10W J 10k Ω	RRXAJR5Z0103
R715	CARBON RES. 1/4W J 100 Ω	RCX4JATZ0101
R716	CARBON RES. 1/4W J 100 Ω	RCX4JATZ0101
R717	CHIP RES. 1/10W J 75 Ω	RRXAJR5Z0750
R718	CHIP RES. 1/10W J 22k Ω	RRXAJR5Z0223
R719	CHIP RES. 1/10W J 22k Ω	RRXAJR5Z0223
R722	CHIP RES. 1/10W J 75 Ω	RRXAJR5Z0750
R725	CHIP RES. 1/10W J 75 Ω	RRXAJR5Z0750
R734	CHIP RES. 1/10W J 100 Ω	RRXAJR5Z0101
R736	CHIP RES. 1/10W J 75 Ω	RRXAJR5Z0750
R738	CHIP RES. 1/10W J 100 Ω	RRXAJR5Z0101
R739	CHIP RES. 1/10W J 100 Ω	RRXAJR5Z0101
R742	CHIP RES. 1/10W J 75 Ω	RRXAJR5Z0750
R744	CHIP RES. 1/10W J 75 Ω	RRXAJR5Z0750
R756	CHIP RES. 1/10W J 22k Ω	RRXAJR5Z0223
R759	CHIP RES. 1/10W J 22k Ω	RRXAJR5Z0223
R783	CHIP RES.(1608) 1/10W 0 Ω	RRXAZR5Z0000
R786	CHIP RES.(1608) 1/10W 0 Ω	RRXAZR5Z0000
R797	CHIP RES. 1/10W J 3.9k Ω	RRXAJR5Z0392
R798	CHIP RES. 1/10W J 10k Ω	RRXAJR5Z0103
R799	CHIP RES. 1/10W J 10k Ω	RRXAJR5Z0103
R805▲	METAL RESISTER. 2W J 2.7 Ω	RN022R7ZU001
R807▲	METAL OXIDE FILM RES. 2W J 2.2 Ω	RN022R2ZU001
R808	CHIP RES. 1/10W J 2.2k Ω	RRXAJR5Z0222
R809	CHIP RES. 1/10W J 4.7k Ω	RRXAJR5Z0472
R810	CHIP RES. 1/10W J 10k Ω	RRXAJR5Z0103
R811	CARBON RES. 1/4W J 10k Ω	RCX4JATZ0103
R812	CHIP RES. 1/10W J 4.7k Ω	RRXAJR5Z0472
R813	CHIP RES. 1/10W J 47k Ω	RRXAJR5Z0473
R814	CHIP RES. 1/10W J 22k Ω	RRXAJR5Z0223
R815	CARBON RES. 1/4W J 180 Ω	RCX4JATZ0181
R816	CHIP RES. 1/10W J 22k Ω	RRXAJR5Z0223
R817	CHIP RES. 1/10W J 47k Ω	RRXAJR5Z0473
R818	CHIP RES. 1/10W J 8.2k Ω	RRXAJR5Z0822
R819	CARBON RES. 1/4W J 180 Ω	RCX4JATZ0181
R820	CHIP RES. 1/10W J 100k Ω	RRXAJR5Z0104
R821	PCB JUMPER D0.6-P5.0	JW5.0T
R822	CHIP RES. 1/10W J 100k Ω	RRXAJR5Z0104
R823	CHIP RES. 1/10W J 100k Ω	RRXAJR5Z0104
R824	CHIP RES. 1/10W J 100k Ω	RRXAJR5Z0104
R825	CHIP RES. 1/10W J 100k Ω	RRXAJR5Z0104
R826	CHIP RES. 1/10W J 100k Ω	RRXAJR5Z0104
R827	CHIP RES. 1/10W J 100k Ω	RRXAJR5Z0104
R828	CHIP RES. 1/10W J 100k Ω	RRXAJR5Z0104
R829	CHIP RES. 1/10W J 100k Ω	RRXAJR5Z0104
R830	CHIP RES. 1/10W J 100k Ω	RRXAJR5Z0104
R831	CHIP RES. 1/10W J 100k Ω	RRXAJR5Z0104
R832	CHIP RES. 1/10W J 100k Ω	RRXAJR5Z0104
R833	CHIP RES. 1/10W J 100k Ω	RRXAJR5Z0104
R834	CHIP RES. 1/10W J 100k Ω	RRXAJR5Z0104
R837	CHIP RES. 1/10W J 1k Ω	RRXAJR5Z0102
R838	CARBON RES. 1/4W J 12k Ω	RCX4JATZ0123
R839	CHIP RES. 1/10W J 12k Ω	RRXAJR5Z0123
R840	CHIP RES. 1/10W J 1.5k Ω	RRXAJR5Z0152
R842	CHIP RES. 1/10W J 100k Ω	RRXAJR5Z0104
R843	CARBON RES. 1/4W J 100k Ω	RCX4JATZ0104

Ref. No.	Description	Part No.
R844	CHIP RES. 1/10W J 2.2k Ω	RRXAJR5Z0222
R851	CHIP RES. 1/10W J 100 Ω	RRXAJR5Z0101
R852	CHIP RES. 1/10W J 100 Ω	RRXAJR5Z0101
R853	CHIP RES. 1/10W J 3.3k Ω	RRXAJR5Z0332
R855	CHIP RES. 1/10W J 180k Ω	RRXAJR5Z0184
R900	CHIP RES. 1/10W J 22k Ω	RRXAJR5Z0223
R901	CARBON RES. 1/4W J 3.3 Ω	RCX4JATZ03R3
R906	METAL OXIDE FILM RES. 2W J 5.6 Ω	RN025R6ZU001
R907	CARBON RES. 1/4W J 470 Ω	RCX4JATZ0471
R908	CHIP RES. 1/10W F 3.3k Ω	RRXAFR5H3301
R909	CHIP RES. 1/10W F 10k Ω	RRXAFR5H1002
R910	METAL OXIDE FILM RES. 2W J 10 Ω	RN02100ZU001
R911	CARBON RES. 1/4W J 470 Ω	RCX4JATZ0471
R912	CHIP RES. 1/10W F 3.3k Ω	RRXAFR5H3301
R913	CHIP RES. 1/10W F 10k Ω	RRXAFR5H1002
R914	CARBON RES. 1/2W J 1.0 Ω	RCX2JZQZ01R0
R915	CHIP RES. 1/10W J 1.2k Ω	RRXAJR5Z0122
R916	CHIP RES. 1/10W J 47k Ω	RRXAJR5Z0473
R917	CARBON RES. 1/4W J 1.8 Ω	RCX4JATZ01R8
R918	CARBON RES. 1/4W J 470 Ω	RCX4JATZ0471
R919	CARBON RES. 1/4W J 470 Ω	RCX4JATZ0471
R921	CARBON RES. 1/4W J 10k Ω	RCX4JATZ0103
R922	CARBON RES. 1/4W J 47k Ω	RCX4JATZ0473
R923	CARBON RES. 1/4W J 1k Ω	RCX4JATZ0102
R924	CHIP RES. 1/10W J 10k Ω	RRXAJR5Z0103
R925	CARBON RES. 1/4W J 10k Ω	RCX4JATZ0103
R926	CARBON RES. 1/4W J 1.8 Ω	RCX4JATZ01R8
R927	CARBON RES. 1/4W J 470 Ω	RCX4JATZ0471
R928	CARBON RES. 1/4W J 470 Ω	RCX4JATZ0471
R929	CARBON RES. 1/4W J 1.5 Ω	RCX4JATZ01R5
R930	PCB JUMPER D0.6-P5.0	JW5.0T
R931	CARBON RES. 1/4W J 22 Ω	RCX4JATZ0220
R932	CARBON RES. 1/4W J 560 Ω	RCX4JATZ0561
R933	CHIP RES. 1/10W F 3.3k Ω	RRXAFR5H3301
R934	CHIP RES. 1/10W F 10k Ω	RRXAFR5H1002
R935	CARBON RES. 1/4W J 2.2 Ω	RCX4JATZ02R2
R936	CARBON RES. 1/4W J 2.2 Ω	RCX4JATZ02R2
R937	CARBON RES. 1/4W J 680 Ω	RCX4JATZ0681
R938	CHIP RES. 1/10W F 220 Ω	RRXAFR5H2200
R939	CHIP RES. 1/10W F 22k Ω	RRXAFR5H2202
R940	CARBON RES. 1/4W J 10k Ω	RCX4JATZ0103
R941	CARBON RES. 1/4W J 3.3k Ω	RCX4JATZ0332
R942	CHIP RES. 1/10W J 10k Ω	RRXAJR5Z0103
R943	CHIP RES. 1/10W J 10k Ω	RRXAJR5Z0103
R949	CARBON RES. 1/4W J 10k Ω	RCX4JATZ0103
R952	CARBON RES. 1/4W J 470 Ω	RCX4JATZ0471
R953	CARBON RES. 1/4W J 12k Ω	RCX4JATZ0123
R954	CARBON RES. 1/4W J 390 Ω	RCX4JATZ0391
R955	CARBON RES. 1/4W J 6.8k Ω	RCX4JATZ0682
R956	CHIP RES. 1/10W F 470 Ω	RRXAFR5H4700
R957	CHIP RES. 1/10W F 10k Ω	RRXAFR5H1002
R958▲	CHIP RES. 1/10W F 6.8k Ω	RRXAFR5H6801
R959▲	CHIP RES. 1/10W F 6.8k Ω	RRXAFR5H6801
R960▲	CHIP RES. 1/10W F 5.6k Ω	RRXAFR5H5601
R961▲	CHIP RES. 1/10W F 5.6k Ω	RRXAFR5H5601
R962▲	CHIP RES. 1/10W F 300 Ω	RRXAFR5H3000
R963▲	CHIP RES. 1/10W F 300 Ω	RRXAFR5H3000
R964▲	CHIP RES. 1/10W F 300 Ω	RRXAFR5H3000
R965▲	CHIP RES. 1/10W F 300 Ω	RRXAFR5H3000
R966	CARBON RES. 1/4W J 22 Ω	RCX4JATZ0220
R968	CHIP RES. 1/10W J 68k Ω	RRXAJR5Z0683
R969	CHIP RES. 1/10W J 1k Ω	RRXAJR5Z0102
R970	CARBON RES. 1/4W J 47 Ω	RCX4JATZ0470

Ref. No.	Description	Part No.
R971	CARBON RES. 1/4W J 1k Ω	RCX4JATZ0102
R974	PCB JUMPER D0.6-P5.0	JW5.0T
R982	METAL OXIDE FILM RES. 1W J 0.39 Ω	RN01R39ZU001
R985	CHIP RES. 1/10W F 3.3k Ω	RRXAFR5H3301
R986	CHIP RES. 1/10W F 6.8k Ω	RRXAFR5H6801
R988	CARBON RES. 1/4W J 10k Ω	RCX4JATZ0103
R992	CHIP RES. 1/10W J 1k Ω	RRXAJR5Z0102
R993	CHIP RES. 1/10W J 3.3k Ω	RRXAJR5Z0332
R996	PCB JUMPER D0.6-P5.0	JW5.0T
R997	CARBON RES. 1/4W J 47k Ω	RCX4JATZ0473
R998	CHIP RES. 1/10W J 150 Ω	RRXAJR5Z0151
R1001	CHIP RES. 1/10W J 3.3k Ω	RRXAJR5Z0332
R1002	CHIP RES. 1/10W J 10k Ω	RRXAJR5Z0103
R1003	CHIP RES. 1/10W J 3.3k Ω	RRXAJR5Z0332
R1004	CHIP RES. 1/10W J 27k Ω	RRXAJR5Z0273
R1005	CARBON RES. 1/4W J 4.7k Ω	RCX4JATZ0472
R1006	CHIP RES. 1/10W J 1.5k Ω	RRXAJR5Z0152
R1007	CARBON RES. 1/4W J 100 Ω	RCX4JATZ0101
R1008	CHIP RES. 1/10W F 10k Ω	RRXAFR5H1002
R1009	CHIP RES.(1608) 1/10W 0 Ω	RRXAZR5Z0000
R1010	CHIP RES. 1/10W F 3k Ω	RRXAFR5H3001
R1011	CHIP RES.(1608) 1/10W 0 Ω	RRXAZR5Z0000
R1013	CARBON RES. 1/4W J 47k Ω	RCX4JATZ0473
R1014	CHIP RES. 1/10W J 3.3k Ω	RRXAJR5Z0332
R1015	CHIP RES. 1/10W J 10k Ω	RRXAJR5Z0103
R1016	CHIP RES. 1/10W J 3.3k Ω	RRXAJR5Z0332
R1017	CARBON RES. 1/4W J 27k Ω	RCX4JATZ0273
R1018	CARBON RES. 1/4W J 1.5k Ω	RCX4JATZ0152
R1019	CHIP RES. 1/10W J 22k Ω	RRXAJR5Z0223
R1020	CHIP RES. 1/10W J 10k Ω	RRXAJR5Z0103
R1021	CARBON RES. 1/4W J 150 Ω	RCX4JATZ0151
R1022	CHIP RES. 1/10W J 47k Ω	RRXAJR5Z0473
R1023	CHIP RES. 1/10W J 56k Ω	RRXAJR5Z0563
R1024	PCB JUMPER D0.6-P5.0	JW5.0T
R1201	CHIP RES.(1608) 1/10W 0 Ω	RRXAZR5Z0000
R1203	CARBON RES. 1/4W J 33 Ω	RCX4JATZ0330
R1204	CHIP RES. 1/10W J 33 Ω	RRXAJR5Z0330
R1205	CARBON RES. 1/4W J 33 Ω	RCX4JATZ0330
R1207	CARBON RES. 1/4W J 33 Ω	RCX4JATZ0330
R1208	CARBON RES. 1/4W J 33 Ω	RCX4JATZ0330
R1209	CHIP RES. 1/10W J 56 Ω	RRXAJR5Z0560
R1210	CHIP RES. 1/10W J 56 Ω	RRXAJR5Z0560
R1211	CHIP RES. 1/10W J 56 Ω	RRXAJR5Z0560
R1212	CHIP RES. 1/10W J 56 Ω	RRXAJR5Z0560
R1213	CHIP RES. 1/10W J 56 Ω	RRXAJR5Z0560
R1214	CHIP RES. 1/10W J 56 Ω	RRXAJR5Z0560
R1215	CHIP RES. 1/10W J 56 Ω	RRXAJR5Z0560
R1216	CHIP RES. 1/10W J 56 Ω	RRXAJR5Z0560
R1217	CHIP RES. 1/10W J 56 Ω	RRXAJR5Z0560
R1218	CHIP RES. 1/10W J 56 Ω	RRXAJR5Z0560
R1219	CHIP RES. 1/10W J 56 Ω	RRXAJR5Z0560
R1220	CHIP RES. 1/10W J 56 Ω	RRXAJR5Z0560
R1221	CHIP RES. 1/10W J 56 Ω	RRXAJR5Z0560
R1222	CHIP RES. 1/10W J 56 Ω	RRXAJR5Z0560
R1223	CHIP RES. 1/10W J 56 Ω	RRXAJR5Z0560
R1224	CHIP RES. 1/10W J 56 Ω	RRXAJR5Z0560
R1225	CHIP RES. 1/10W J 56 Ω	RRXAJR5Z0560
R1226	CHIP RES. 1/10W J 56 Ω	RRXAJR5Z0560
R1227	CHIP RES. 1/10W J 56 Ω	RRXAJR5Z0560
R1228	CHIP RES. 1/10W F 10k Ω	RRXAFR5H1002
R1229	CHIP RES. 1/10W J 1k Ω	RRXAJR5Z0102
R1230	CHIP RES. 1/10W J 56 Ω	RRXAJR5Z0560
R1231	CHIP RES. 1/10W J 56 Ω	RRXAJR5Z0560

Ref. No.	Description	Part No.
R1233	CHIP RES. 1/10W J 56 Ω	RRXAJR5Z0560
R1234	CHIP RES. 1/10W J 56 Ω	RRXAJR5Z0560
R1235	CHIP RES. 1/10W J 56 Ω	RRXAJR5Z0560
R1236	CHIP RES. 1/10W J 56 Ω	RRXAJR5Z0560
R1237	CHIP RES. 1/10W J 56 Ω	RRXAJR5Z0560
R1238	CHIP RES. 1/10W J 56 Ω	RRXAJR5Z0560
R1239	CHIP RES. 1/10W J 56 Ω	RRXAJR5Z0560
R1240	CHIP RES. 1/10W J 56 Ω	RRXAJR5Z0560
R1241	CHIP RES. 1/10W J 1k Ω	RRXAJR5Z0102
R1242	CHIP RES. 1/10W J 22k Ω	RRXAJR5Z0223
R1248	CHIP RES. 1/10W J 56 Ω	RRXAJR5Z0560
R1249	CHIP RES. 1/10W J 56 Ω	RRXAJR5Z0560
R1250	CHIP RES. 1/10W J 56 Ω	RRXAJR5Z0560
R1251	CHIP RES. 1/10W J 56 Ω	RRXAJR5Z0560
R1252	CHIP RES. 1/10W J 56 Ω	RRXAJR5Z0560
R1253	CHIP RES. 1/10W J 56 Ω	RRXAJR5Z0560
R1254	CHIP RES. 1/10W J 56 Ω	RRXAJR5Z0560
R1255	CHIP RES. 1/10W J 56 Ω	RRXAJR5Z0560
R1256	CHIP RES. 1/10W J 56 Ω	RRXAJR5Z0560
R1257	CHIP RES. 1/10W J 56 Ω	RRXAJR5Z0560
R1258	CHIP RES. 1/10W J 56 Ω	RRXAJR5Z0560
R1259	CHIP RES. 1/10W J 56 Ω	RRXAJR5Z0560
R1260	CHIP RES. 1/10W J 56 Ω	RRXAJR5Z0560
R1307	CHIP RES. 1/10W J 33 Ω	RRXAJR5Z0330
R1308	CHIP RES. 1/10W J 33 Ω	RRXAJR5Z0330
R1311	CHIP RES. 1/10W J 33 Ω	RRXAJR5Z0330
R1312	CHIP RES. 1/10W J 100 Ω	RRXAJR5Z0101
R1313	CHIP RES. 1/10W J 10k Ω	RRXAJR5Z0103
R1314	CHIP RES. 1/10W J 100 Ω	RRXAJR5Z0101
R1315	CHIP RES. 1/10W J 10k Ω	RRXAJR5Z0103
R1316	CHIP RES. 1/10W J 10k Ω	RRXAJR5Z0103
R1318	CHIP RES. 1/10W J 10k Ω	RRXAJR5Z0103
R1323	CHIP RES. 1/10W J 33 Ω	RRXAJR5Z0330
R1324	CHIP RES. 1/10W J 33 Ω	RRXAJR5Z0330
R1325	CHIP RES. 1/10W J 33 Ω	RRXAJR5Z0330
R1326	CHIP RES. 1/10W J 560 Ω	RRXAJR5Z0561
R1327	CHIP RES. 1/10W J 47 Ω	RRXAJR5Z0470
R1328	CHIP RES. 1/10W J 470 Ω	RRXAJR5Z0471
R1329	CHIP RES. 1/10W J 33 Ω	RRXAJR5Z0330
R1330	CHIP RES. 1/10W J 33 Ω	RRXAJR5Z0330
R1336	CHIP RES. 1/10W J 56 Ω	RRXAJR5Z0560
R1337	CHIP RES. 1/10W J 1M Ω	RRXAJR5Z0105
R1338	CHIP RES. 1/10W J 33 Ω	RRXAJR5Z0330
R1339	CARBON RES. 1/4W J 33 Ω	RCX4JATZ0330
R1340	CHIP RES.(1608) 1/10W 0 Ω	RRXAZR5Z0000
R1341	CHIP RES. 1/10W J 33 Ω	RRXAJR5Z0330
R1342	CHIP RES. 1/10W J 4.7k Ω	RRXAJR5Z0472
R1343	CHIP RES. 1/10W J 100 Ω	RRXAJR5Z0101
R1344	CHIP RES. 1/10W J 10k Ω	RRXAJR5Z0103
R1345	CHIP RES.(1608) 1/10W 0 Ω	RRXAZR5Z0000
R1346	CHIP RES. 1/10W J 10k Ω	RRXAJR5Z0103
R1347	CHIP RES.(1608) 1/10W 0 Ω	RRXAZR5Z0000
R1348	CHIP RES. 1/10W J 100 Ω	RRXAJR5Z0101
R1349	CHIP RES. 1/10W J 100 Ω	RRXAJR5Z0101
R1350	CHIP RES.(1608) 1/10W 0 Ω	RRXAZR5Z0000
R1352	CHIP RES. 1/10W J 4.7k Ω	RRXAJR5Z0472
R1353	CHIP RES. 1/10W J 15k Ω	RRXAJR5Z0153
R1354	CHIP RES. 1/10W J 100 Ω	RRXAJR5Z0101
R1359	CHIP RES. 1/10W J 10k Ω	RRXAJR5Z0103
R1360	CHIP RES. 1/10W J 10k Ω	RRXAJR5Z0103
R1361	CHIP RES. 1/10W J 2.2k Ω	RRXAJR5Z0222
R1362	CHIP RES. 1/10W J 33 Ω	RRXAJR5Z0330
R1363	CHIP RES. 1/10W J 1k Ω	RRXAJR5Z0102

Ref. No.	Description	Part No.
R1364	CHIP RES. 1/10W J 1k Ω	RRXAJR5Z0102
R1710	CHIP RES. 1/10W J 10k Ω	RRXAJR5Z0103
MISCELLANEOUS		
AC601▲	AC CORD A0A0280-007	WAC0172LTE04
B10	POW HEAT SINK A7120UH	1EM423993
BC61	BEADS INDUCTOR FBR07HA121SB-00	LLBF00STU030
BC62	BEADS INDUCTOR FBR07HA121SB-00	LLBF00STU030
BC65	PCB JUMPER D0.6-P5.0	JW5.0T
BC602	BEADS INDUCTOR FBR07HA121SB-00	LLBF00STU030
BC901	BEADS INDUCTOR FBR07HA121SB-00	LLBF00STU030
BC902	BEADS INDUCTOR FBR07HA121SB-00	LLBF00STU030
BC903	BEADS INDUCTOR FBR07HA121SB-00	LLBF00STU030
BC904	BEADS INDUCTOR FBR07HA121SB-00	LLBF00STU030
CF31	CERAMIC FILTER SFSRA4M50CF00-B0	FBB455PMR004
F601▲	FUSE STC4A125V U/CT	PAGE20CW3402
FH601	FUSE HOLDER MSF-015 LF (B110)	XH01Z00LY002
FH602	FUSE HOLDER MSF-015 LF (B110)	XH01Z00LY002
GP642▲	GAP. FNR-G3.10D	FAZ000LD6005
JK701	Y/C JACK YKF51-5646N	JYEJ040JC001
JK703	RCA JACK AV-4B-54H YELLOW	JXRJ010SNJ01
JK704	RCA JACK WHITE AV-4B-58H WHITE	JXRJ010SNJ04
JK705	RCA JACK AV-4A-57H RED	JYRJ010SNJ01
JK706	RCA JACK AV-4B-55H	JXRJ010SNJ05
JK707	RCA JACK AV-4B-56H	JXRJ010SNJ02
JK708	RCA JACK AV-4B-57H	JXRJ010SNJ03
JK709	RCA JACK WHITE AV-4B-58H WHITE	JXRJ010SNJ04
JK710	RCA JACK AV-4A-57H RED	JYRJ010SNJ01
JK801	MINIATURE JACK(PB FREE) CKX-035-318AZ4	JJSL010SNJ01
JK1701	JACK RCA PCB S AV-4B-70HH	JXRJ010SNJ06
JS67	PCB JUMPER D0.6-P5.5	JW5.5T
JS426	PCB JUMPER D0.6-P5.0	JW5.0T
JS446	PCB JUMPER D0.6-P17.5	JW17.5T
JS466	PCB JUMPER D0.6-P22.5	JW22.5T
JS701	PCB JUMPER D0.6-P5.0	JW5.0T
JS702	PCB JUMPER D0.6-P5.0	JW5.0T
JS703	PCB JUMPER D0.6-P5.0	JW5.0T
JS704	CHIP RES.(1608) 1/10W 0 Ω	RRXAZR5Z0000
JS705	PCB JUMPER D0.6-P5.0	JW5.0T
L9	SCREW B-TIGHT D3X8 BIND HEAD+	GBJB3080
SA601▲	SURGE ABSORBER 470V+-10PER	NVQZ10D471KB
SF11	FILTER CERAMIC BAND PASS SAFHS45M7VAJZ00B05	FBB456LMR004
T401▲	TRANS INVERTER ETJV27ZK27AC	LTZ2PC0MS006
T402▲	TRANS INVERTER ETJV27ZK27AC	LTZ2PC0MS006
T403▲	TRANS INVERTER ETJV27ZK27AC	LTZ2PC0MS006
T601▲	TRANS POWER 7709	LTT2PC0KT021
TU61	TUNER UNIT ENV56M07D8F	UTUNATSMS001
X1301	XTAL OSCILLATOR 27.00MHz 15PPM	FXC276LLN002

ANALOG KEY CBA

Ref. No.	Description	Part No.
	ANALOG KEY CBA Consists of the following:	1ESA13885
	FUNCTION CBA	-----
	IR SENSOR CBA	-----
	JUNCTION-A CBA	-----
	JUNCTION-B CBA	-----

FUNCTION CBA

Ref. No.	Description	Part No.
	FUNCTION CBA Consists of the following:	-----
RESISTORS		

Ref. No.	Description	Part No.
R1101	CARBON RES. 1/4W J 10k Ω	RCX4JATZ0103
R1102	CARBON RES. 1/4W J 100 Ω	RCX4JATZ0101
R1103	CARBON RES. 1/4W J 1.5k Ω	RCX4JATZ0152
R1104	CARBON RES. 1/4W J 1.5k Ω	RCX4JATZ0152
R1105	CARBON RES. 1/4W J 2.2k Ω	RCX4JATZ0222
R1106	CARBON RES. 1/4W J 2.7k Ω	RCX4JATZ0272
R1107	CARBON RES. 1/4W J 4.7k Ω	RCX4JATZ0472
R1108	CARBON RES. 1/4W J 6.8k Ω	RCX4JATZ0682
R1109	CARBON RES. 1/4W J 10k Ω	RCX4JATZ0103
R1110	CARBON RES. 1/4W J 100 Ω	RCX4JATZ0101
SWITCHES		
SW1101	TACT SWITCH SKQSAB	SST0101AL038
SW1102	TACT SWITCH SKQSAB	SST0101AL038
SW1103	TACT SWITCH SKQSAB	SST0101AL038
SW1104	TACT SWITCH SKQSAB	SST0101AL038
SW1105	TACT SWITCH SKQSAB	SST0101AL038
SW1107	TACT SWITCH SKQSAB	SST0101AL038
SW1111	TACT SWITCH SKQSAB	SST0101AL038
MISCELLANEOUS		
CL1107	WIRE ASSEMBLY 4PIN SW 20V 4PIN/128MM	WX1A7140-001

IR SENSOR CBA

Ref. No.	Description	Part No.
	IR SENSOR CBA Consists of the following:	-----
CAPACITOR		
C1142	ELECTROLYTIC CAP. 2.2 μ F/50V M H7	CE1JMAVSL2R2
RESISTOR		
R1143	CARBON RES. 1/4W J 120 Ω	RCX4JATZ0121
MISCELLANEOUS		
CL1104	WIRE ASSEMBLY 5PIN SENSOR 20V 5PIN/ 305MM	WX1A7140-002
RV1142	REMOCON RECEIVE UNIT KSM-602SR2E-2	USESJRSKK045

JUNCTION-A CBA

Ref. No.	Description	Part No.
	JUNCTION-A CBA Consists of the following:	-----
MISCELLANEOUS		
CL801	WIRE ASSEMBLY 2PIN SPEAKER 20V 2PIN/ 230MM	WX1A7140-007

JUNCTION-B CBA

Ref. No.	Description	Part No.
	JUNCTION-B CBA Consists of the following:	-----
MISCELLANEOUS		
CL802	WIRE ASSEMBLY 2PIN SPEAKER 20V 2PIN/ 230MM	WX1A7140-007

© 2007 Funai Electric Co., Ltd.

All rights reserved. No part of this manual may be reproduced, copied, transmitted, disseminated, transcribed, downloaded or stored in any storage medium, in any form or for any purpose without the express prior written consent of Funai. Furthermore, any unauthorized commercial distribution of this manual or any revision hereto is strictly prohibited.

Information in this document is subject to change without notice. Funai reserves the right to change the content herein without the obligation to notify any person or organization of such changes.

FUNAI with the  design is a registered trademark of Funai Electric Co., Ltd and may not be used in any way without the express written consent of Funai. All other trademarks used herein remain the exclusive property of their respective owners. Nothing contained in this manual should be construed as granting, by implication or otherwise, any license or right to use any of the trademarks displayed herein. Misuse of any trademarks or any other content in this manual is strictly prohibited. Funai shall aggressively enforce its intellectual property rights to the fullest extent of the law.